

CATALOG 2025

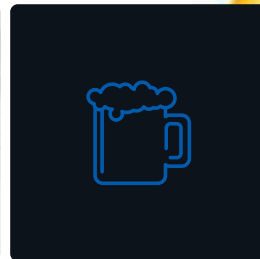

PROFESSIONAL KITCHEN EQUIPMENTS

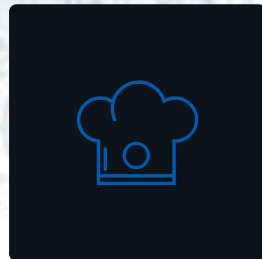
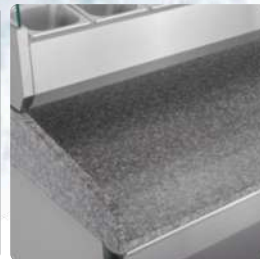

PROFESSIONAL
KITCHEN
EQUIPMENTS

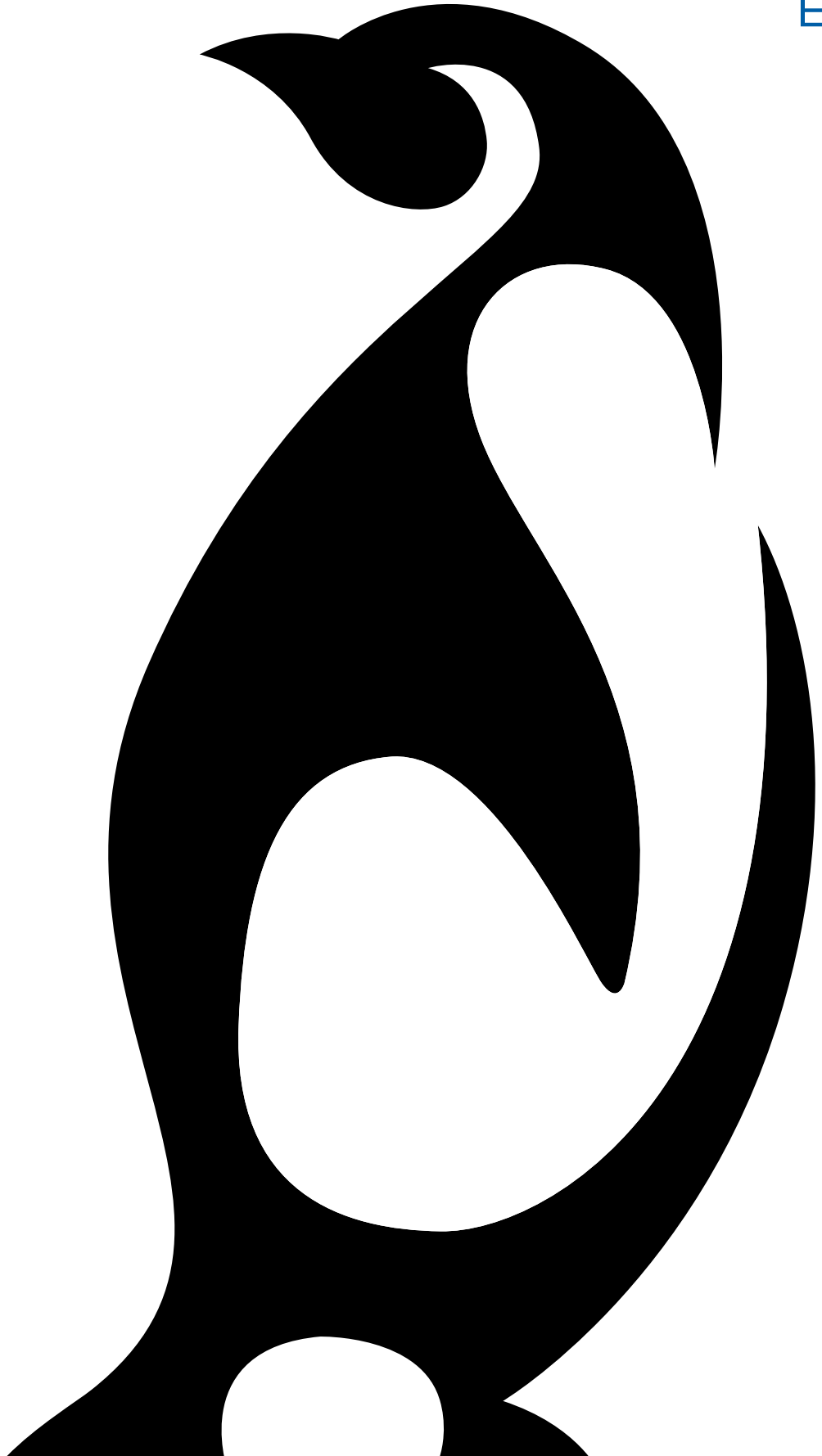

Saliba

www.salibaequipment.com

CONTENTS



PIZZA FORMER

- 09 Saliba Former
- 11 Saliba Former pizza counter refrigerator



SALIBA IMPASTO

- 16 Spiral mixers
- 18 Planetary mixers



SALADETTE SERIES

- 21 Cooling top display
- 33 Saladette
- 53 Ventilated salad counter
- 55 Cocktail station chiller
- 57 Open top table salad counter



STAINLESS STEEL KITCHEN SERIES

- 61 Counter chiller/freezer
- 65 Glass door counter chiller
- 67 Counter chiller/freezer with drawers
- 79 650mm counter
- 83 Chef drawer

- 87 Single door upright chiller/freezer
- 95 Double door upright chiller/freezer
- 97 Three door upright chiller/freezer
- 99 Upper and lower door upright chiller/freezer
- 101 Four door upright chiller/freezer
- 103 Six door upright chiller/freezer
- 105 Glass door upright chiller/freezer
- 109 Combined temperature



PIZZA SANDWICH

- 115 Sandwich counter
- 121 Pizza counter
- 123 Luxury pizza counter
- 127 Subway



BAKERY SHOWCASE

- 131 Blast chiller/freezer
- 137 Blast chiller/freezer
- 137 Bakery refrigerator & freezer
- 139 Bakery upright
- 143 Showcase series



BEVERAGE SHOWCASE SERIES

- 201 Black beer cabinet
- 203 Stainless steel beer cabinet
- 207 Upright beverage cooler
- 209 Under counter



COOKED FOOD AIR DRIED HANGING MEAT

- 213 Meat display refrigerator
- 215 Lower hanging meat cabinet
- 217 Luxury air-drying cabinet



OTHER SERIES

- 221 Ice storage cabinet
- 223 Solid waste refrigerator
- 225 Cooling wells



TABLE TOP SERIES

- 229 Cookers and fryers
- 231 Electric clamp grills
- 232 Kebab grills



ABOUT Saliba GastroTeam



GastroTeam Abbe AB established in 2014, the company is located in the city of Bankeryd in Sweden.

We are professional manufacturers specialized in producing and selling high quality commercial kitchen equipments under Saliba brand. We aim at both domestic and oversea market, and winning popularity and good reputation in market with our principle of superior quality and best service.

At present, our products cover Pizza Former, Dough Spiral and Planetary Mixers, Saladette, Refrigerated Counter and Pizza Table, Cooling Pizza display, Upright Cabinets, Blast Chiller Freezer and Cake Display. All our products are made with Stainless steel AISI 304, and base European standard which are CE, LFGB, ROHS and 3C etc. certificated. Furthermore we also produce fryers and doner machines under our other brand 2NORTH. We always comply with the principle "Development and Innovation", and keep improving and developing the products.

GastroTeam and the staff warmly welcome friends and partners to visit our company and do business with us.



Saliba Former



PIZZA
FORMER

Pizzaformer



SALIBA FORMER

Pizzaformer

Product features

- Easy to Clean
- User Friendly Design
- Build Body Desing
- Ø 28 – Ø 35 cm Pizza Base
- 180 Pizza/ Hour
- Non-Stick Surface

Saliba Former

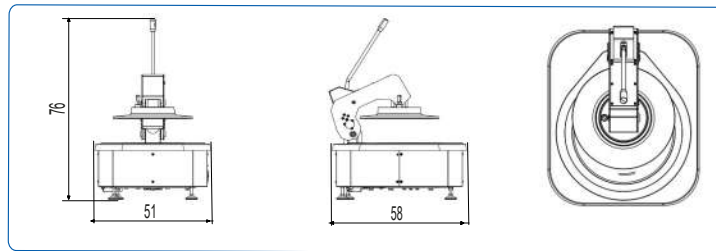

Model	GTSF-ECL	GTSF-ECL-TB
Capacity Daugh Balls/	1-2/ 180 Pizza/hour	1-2/ 180 Pizzahour
Product Size(mm)	510x580x910	645x830x1060
Voltage(V/Hz)	230V~50/60	230V~50/60
Rated Power(W)	350	350
Net Weight(Kg)	85	160

Product certification



* We have the right to change the product design and configuration without informing customers in advance!

SALIBA FORMER

Pizzaformer

Product features

- Pizza former with stand
- Lockable wheels
- Marble top
- Adaptable for trays 40x60 & 45x60
- Four neutral drawers

Saliba Former Build in Cabinet

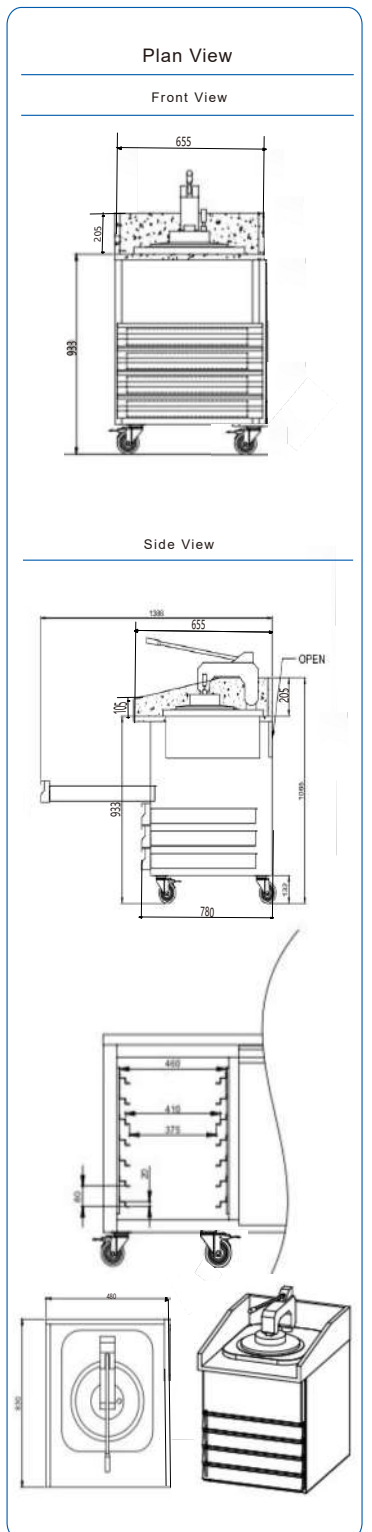

SALIBA FORMER PIZZA COUNTER REFRIGERATOR

Product features

- 304 Stainless Steel
- Embraco/ Secop Compressors
- Evco Controller
- Ventilated System
- Wheels
- 1/3 GN Container Adaptable
- Pizzaformer fit inside
- 2 Door with 3 drawers



Product details

Pizzaformer



1. Marble top
2. Adjustable feet or castor is available
3. Three drawers
4. GN 1/1 & 40 x 60 mm / 45x60 mm Trays Adaptable Shelves
5. Adjustable shelves
6. Refrigerated Cooling Tops adatable for GN 1/3 pans

Product parameters

Model	GTSF-ELC-PTB
Net Capacity(L)	450
Product Size(mm)	2266x830x1500
Temperature(°C)	-2~+6
Power(W)	366
Net Weight(Kg)	320
Refrigeration Type	Ventilated

Product certification



* We have the right to change the product design and configuration without informing customers in advance!

GTSF-ELC-PTB



GN Pans Configurations

GTSF-ELC-PTB



Plan View

Front View

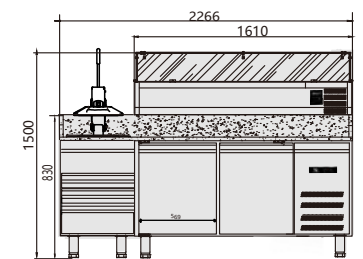

Side View

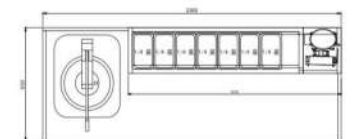
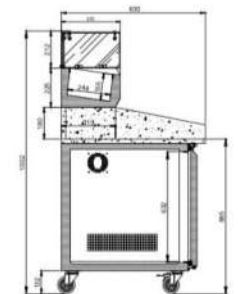
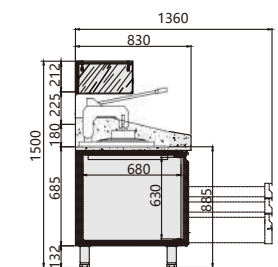



Saliboa
IMPASTO





SPIRAL MIXERS

Product features

- Easy to use, clean & maintain
- Complete Stainless Steel Body, Spiral & Bowl
- Emergency Stop
- Single Engine
- Ideal for all kind of mixing, whisking, & kneading works



DH-60AT



DH-8



DR-40S

Model	DH-60AT	DH-8	DR-40S	
Capacity Water(Lt)/ Flour(KG)	60L30	8/5	Dough Weight(Gr)	50-500
Max. Kneading Capacity(Kg)	30	3	Pizza Diameter (CM)	10-40
Product size(mm)	920x580x1142	495x302x385		540x550x650
Voltage(V/kW)	380~1.5/2.2	220~0.45		220~0.37
Speed (RPM)	2 (135/90)	1 (159)		---
Net Weight(Kg)	220	36		41

Product certification



* We have the right to change the product design and configuration without informing customers in advance!

SPIRAL MIXERS

Product features

- Easy to use, clean & maintain
- Stainless Steel Bowl
- 2 Whisks & 1 Dough Hook are supplied with the machine
- Optional Automatik Bowl Lifting Up & Down
- Speed Controlled Mixers
- Ideal for all kinds of mixing, whisking & kneading works



DH-60A

Model	DH-60A	DH-80
Capacity Water(Lt)/ Flour(Kg)	60/30	80/30
Max. Kneading Capacity(Kg)	25	30
Product size(mm)	940x595x1255	920x580x1142
Voltage(V/kW)	380~1.5/2.4	380~1.5/2.4
Speed (RPM)	2 (240/120)	2 (240/120)
Net Weight(Kg)	20	220

Product certification



* We have the right to change the product design and configuration without informing customers in advance!

PLANETARY MIXERS

Product features

- Easy to use, clean and maintain
- Stainless Steel Bowl
- 2 Whisks and 1 Dough Hook are supplied with the machine
- Optional Automatik Bowl Lifting Up & Down
- Speed Controlled Mixers
- Ideal for all kinds of mixing, whisking and kneading works



M30A



M20A

Model	M20A	M30A
Capacity Water(Lt)/ Flour(KG)	20/8	30/10
Max. Kneading Capacity(Kg)	5	6
Product size(mm)	530x496x880	546x512x852
Voltage(V/ kW)	220~1.1	220~1.4
Speed(RPM)	3 (104/187/365)	3 (140/187/365)
Net Weight (Kg)	87	94

Product certification



* We have the right to change the product design and configuration without informing customers in advance!



GTS-VRX COOLING TOP DISPLAY



GTS-VRX (380) COOLING TOP DISPLAY (S/S LID380)

Product features

- SS cover
- Static cooling system
- Stainless steel structure
- High density insulation body
- Gn1/1 disk can be collocated at any size according to size
- Can be placed on a refrigerated platform cabinet
- Europe brand digital controller
- Europe brand compressor
- Smart automatic defrosting

Product details



1. SS cover
2. GN score disc, match arbitrarily according to size and combine freely



Product parameters

Model	GTS-VRX900/380LID	GTS-VRX1000/380LID	GTS-VRX1100/380LID	GTS-VRX1200/380LID	GTS-VRX1400/380LID
Product size (mm)	900×395×622	1000×395×622	1100×395×622	1200×395×622	1400×395×622
Temperature (°C)	+2~+8	+2~+8	+2~+8	+2~+8	+2~+8
Net weight (Kg)	30	32	35.6	37.8	42.2
Net capacity (L)	30	34	38	40	40
Rated power (W)	198	201	203	206	210
Refrigeration type	Static	Static	Static	Static	Static

Model	GTS-VRX1500/380LID	GTS-VRX1600/380LID	GTS-VRX1800/380LID	GTS-VRX2000/380LID	GTS-VRX2025/380LID
Product size (mm)	1500×395×622	1600×395×622	1800×395×622	2000×395×622	2025×395×622
Temperature (°C)	+2~+8	+2~+8	+2~+8	+2~+8	+2~+8
Net weight (Kg)	45.4	48.6	55	61.4	63.5
Net capacity (L)	44	48	55	63	63
Rated power (W)	212	215	221	227	229
Refrigeration type	Static	Static	Static	Static	Static

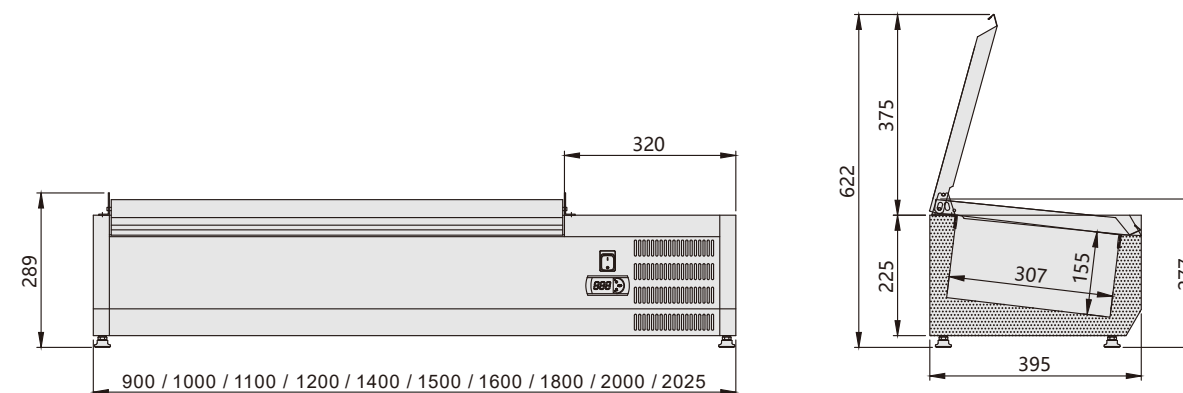

Product certification



* We have the right to change the product design and configuration without informing customers in advance!

GTS-VRX (330) COOLING TOP DISPLAY (S/S LID330)

Product features

- SS cover
- Static cooling system
- Stainless steel structure
- High density insulation body
- G1/1 disk can be collocated at any size according to size
- Can be placed on a refrigerated platform cabinet
- Europe brand digital controller
- Europe brand compressor
- Smart automatic defrosting

Product details



1. The digital temperature control display makes the temperature control more accurate and protects the compressor for a long time
2. Large cooling port maintains a fresh environment and makes the parts more durable



Product parameters

Model	GTS-VRX900/330LID	GTS-VRX1000/330LID	GTS-VRX1100/330LID	GTS-VRX1200/330LID	GTS-VRX1400/330LID
Product size (mm)	900×335×565	1000×335×565	1100×335×565	1200×335×565	1400×335×565
Temperature (°C)	+2~+8	+2~+8	+2~+8	+2~+8	+2~+8
Net weight (Kg)	27.2	30	32	34.6	40
Net capacity (L)	20	24	28	32	40
Rated power (W)	182	185	187	189	194
Refrigeration type	Static	Static	Static	Static	Static

Model	GTS-VRX1500/330LID	GTS-VRX1600/330LID	GTS-VRX1800/330LID	GTS-VRX2000/330LID	GTS-VRX2025/330LID
Product size (mm)	1500×335×565	1600×335×565	1800×335×565	2000×335×565	2025×335×565
Temperature (°C)	+2~+8	+2~+8	+2~+8	+2~+8	+2~+8
Net weight (Kg)	42.7	45.5	51	56.6	56.7
Net capacity (L)	44	48	55	63	64
Rated power (W)	196	198	204	210	212
Refrigeration type	Static	Static	Static	Static	Static

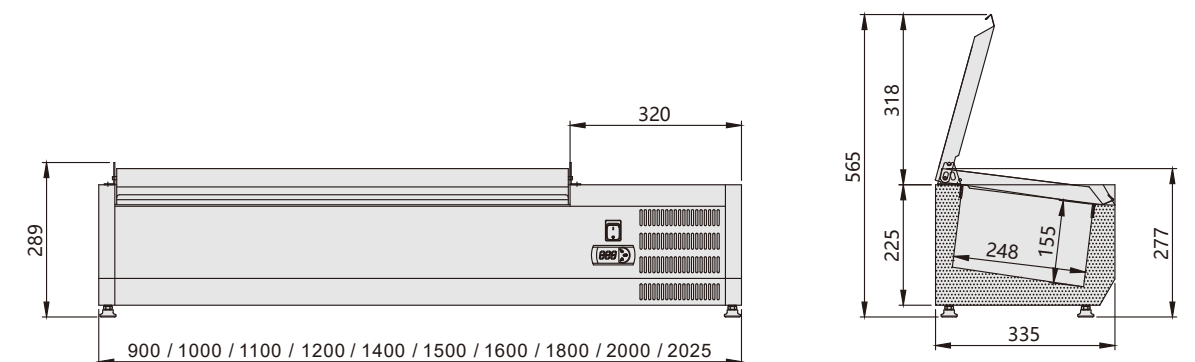

Product certification



* We have the right to change the product design and configuration without Informing customers in advance!

GTS-VRX (380) COOLING TOP DISPLAY (GLASS COVER 380)

Product features

- Glass Cover
- Static cooling system
- Stainless steel structure
- High density insulation body
- Gn1/1 disk can be collocated at any size according to size
- Can be placed on a refrigerated platform cabinet
- Europe brand digital controller
- Europe brand compressor

Product details



1. Glass Cover
2. GN score disc, match arbitrarily according to size and combine freely



Product parameters

Model	GTS-VRX900/380	GTS-VRX1000/380	GTS-VRX1100/380	GTS-VRX1200/380	GTS-VRX1400/380
Product size (mm)	900×395×459	1000×395×459	1100×395×459	1200×395×459	1400×395×459
Temperature (°C)	2~8	2~8	2~8	2~8	2~8
Net weight (Kg)	40	44	47	50	59
Net capacity (L)	30	34	38	40	42
Rated power (W)	177	180	183	186	192
Refrigeration type	Static	Static	Static	Static	Static

Model	GTS-VRX1500/380	GTS-VRX1600/380	GTS-VRX1800/380	GTS-VRX2000/380	GTS-VRX2025/380
Product size (mm)	1500×395×459	1600×395×459	1800×395×459	2000×395×459	2025×395×459
Temperature (°C)	2~8	2~8	2~8	2~8	2~8
Net weight (Kg)	61	65	72	77	79
Net capacity (L)	44	48	55	63	63
Rated power (W)	195	198	204	210	212
Refrigeration type	Static	Static	Static	Static	Static

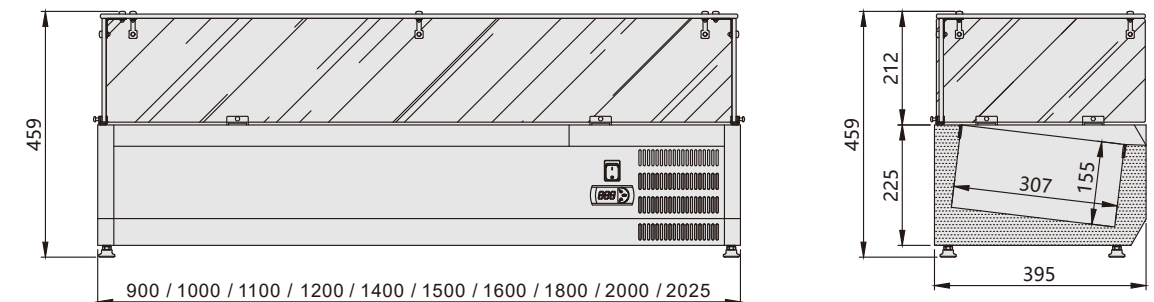

Product certification



* We have the right to change the product design and configuration without informing customers in advance!

GTS-VRX (330) COOLING TOP DISPLAY (GLASS COVER 330)

Product features

- Glass Cover
- Static cooling system
- Stainless steel structure
- High density insulation body
- G1/1 disk can be collocated at any size according to size
- Can be placed on a refrigerated platform cabinet
- Europe brand digital controller
- Europe brand compressor
- Smart automatic defrosting

Product details



1. The digital temperature control display makes the temperature control more accurate and protects the compressor for a long time
2. Large cooling port maintains a fresh environment and makes the parts more durable



Product parameters

Model	GTS-VRX900/330	GTS-VRX1000/330	GTS-VRX1100/330	GTS-VRX1200/330	GTS-VRX1400/330
Product size (mm)	900×335×459	1000×335×459	1100×335×459	1200×335×459	1400×335×459
Temperature (°C)	2~8	2~8	2~8	2~8	2~8
Net weight (Kg)	37	40	44	48	53
Net capacity (L)	20	24	28	32	40
Rated power (W)	172	174	176	178	182
Refrigeration type	Static	Static	Static	Static	Static

Model	GTS-VRX1500/330	GTS-VRX1600/330	GTS-VRX1800/330	GTS-VRX2000/330	GTS-VRX2025/330
Product size (mm)	1500×335×459	1600×335×459	1800×335×459	2000×335×459	2025×335×459
Temperature (°C)	2~8	2~8	2~8	2~8	2~8
Net weight (Kg)	57	60	68	75	76
Net capacity (L)	44	48	55	63	64
Rated power (W)	184	186	190	194	195
Refrigeration type	Static	Static	Static	Static	Static

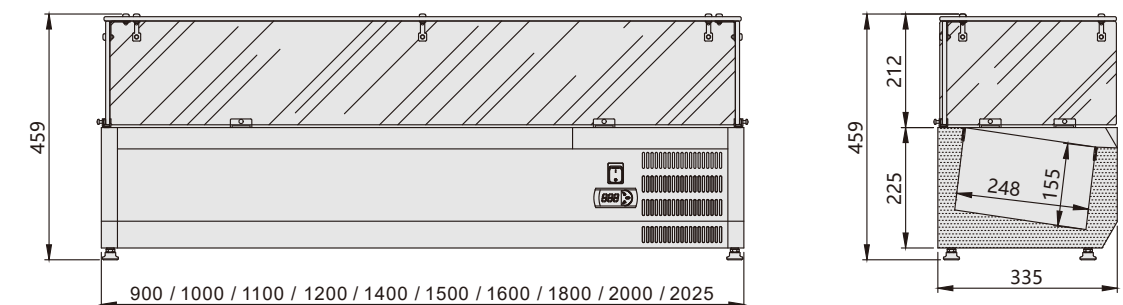

Product certification



* We have the right to change the product design and configuration without informing customers in advance!

GTS-VRX
COOLING TOP DISPLAY



GTS-VRX GN

Cooling Top Display GN Pans Configurations



Customizable width (500mm wide, 600mm wide)

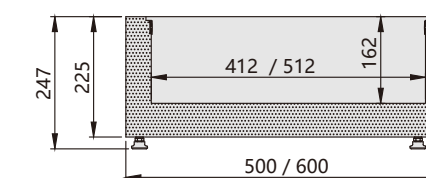
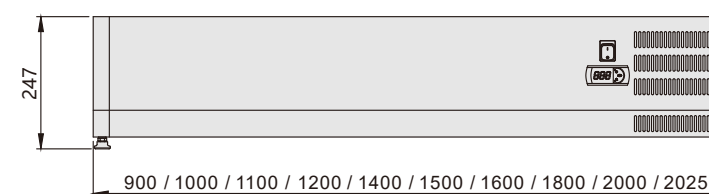



SALADETTE SERIES



SALADETTE WITH SS COVER

Product features

- SS cover , design for GN pans
- High density insulation for cooling system
- Static or ventilated system are available
- Stainless steel structure
- GN1/1 shelf size for operation
- Europe brand controller & Europe brand compressor
- Cutting board with PP
- Round corner hygiene
- Inner bottom use bend line to drain pipe
- Castor is available
- Top quality cooper pipe built-in
- Led light is available
- Magnetic gasket can be changed without tools
- Door easy to change Drawers or Glass door
- The door can be interchanged by drawers

Product details



1. Europe brand controller
2. Chopping board
3. SS cover
4. Adjustable shelving
5. Door handle design
6. Pulley translation stainless steel cover

Product parameters

Model	GTS-S900 STD	GTS-S902 STD	GTS-S903 STD
Product size (mm)	900×700×887	1045×700×887	1365×700×887
Refrigerant	R290	R290	R290
Temperature (°C)	+2~+8	+2~+8	+2~+8
Net weight (Kg)	66	69	87
Net capacity (L)	250	260	390
Rated power (W)	204	290	321
Refrigeration type	Static	Static	Static

Product certification



* We have the right to change the product design and configuration without informing customers in advance!



GTS-S900 STD



GTS-S902 STD



GTS-S903 STD

GN Pans Configurations

GTS-S900 STD



GTS-S902 STD



GTS-S903 STD



Plan View

Front View

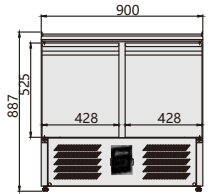

GTS-S900 STD

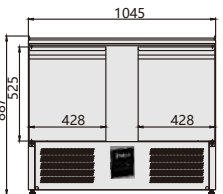

GTS-S902 STD

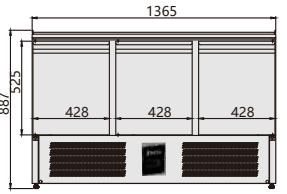

GTS-S903 STD

Side View

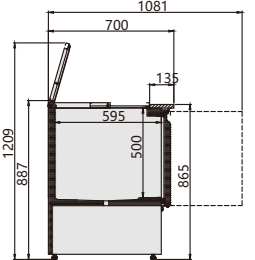

SALADETTE WITH GLASS COVER

Product features

- Glass cover , design for GN pans
- High density insulation for cooling system
- Static or ventilated system are available
- Stainless steel structure
- GN1/1 shelf size for operation
- Europe brand controller & Europe brand compressor
- Cutting board with PP
- Round corner hygiene
- Inner bottom use bend line to drain pipe
- Castor is available
- Top quality cooper pipe built-in
- Led light is available
- Magnetic gasket can be changed without tools
- Door easy to change Drawers or Glass door
- The door can interchanged by drawers

Product details



1. Europe brand controller
2. Chopping board
3. Glass cover, refrigerated and fresh-keeping
4. Adjustable shelving
5. Door handle design
6. GN several plates classified storage, food does not smell

Product parameters

Model	GTS-S900T	GTS-S902T	GTS-S903T
Product size (mm)	900×700×1268	1045×700×1268	1365×700×1268
Refrigerant	R290	R290	R290
Temperature (°C)	+2~+8	+2~+8	+2~+8
Net weight (Kg)	99	120	148
Net capacity (L)	250	260	390
Rated power (W)	204	290	321
Refrigeration type	Static	Static	Static

Product certification



* We have the right to change the product design and configuration without informing customers in advance!



GTS-S900T



GTS-S902T



GTS-S903T

GN Pans Configurations

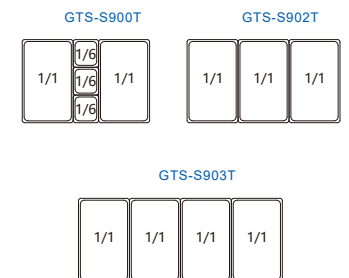

Plan View

Front View

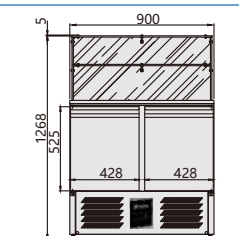

GTS-S900T

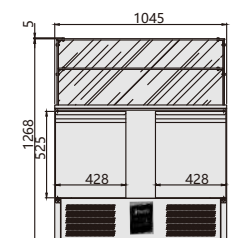

GTS-S902T

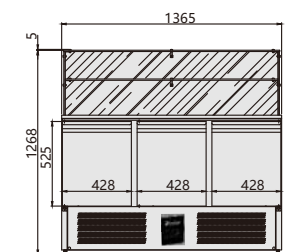

GTS-S903T

Side View

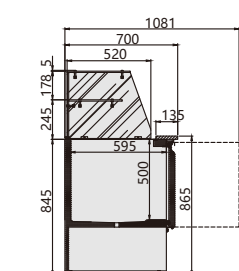

SALADETTE WITH TABLE TOP

Product features

- Open for GN1/6 other GN pans is available
- High density insulation for cooling system
- Static or ventilated system are available
- Stainless steel structure
- GN1/1 shelf size for operation
- Europe brand controller & Europe brand compressor
- Round corner hygiene
- Inner bottom use bend line to drain pipe
- Castor is available
- Top quality cooper pipe built-in
- Led lights available
- Magnetic gasket can be changed without tools
- Door easy to change Drawers or Glass door
- The door can interchanged by drawers

Product details

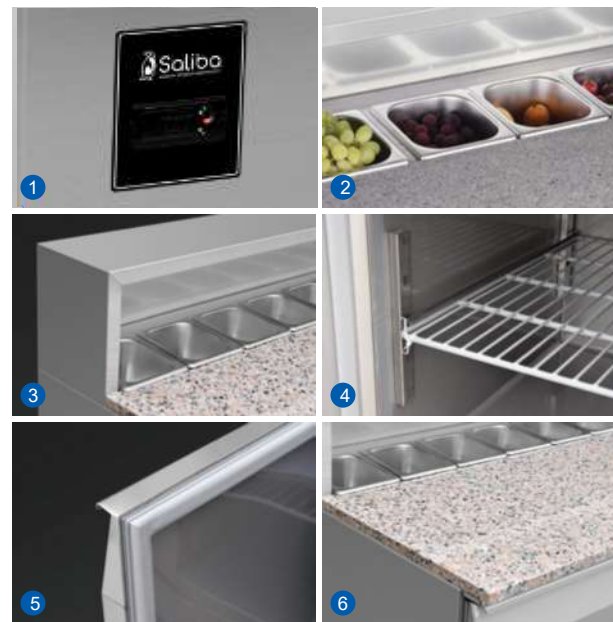

1. Europe brand controller
2. Fractional plate design, classified storage, food does not taste
3. Front opening insulation cover
4. Adjustable shelving
5. Beveled handle design and multiple door seals
6. High quality marble countertop

Product parameters

Model	GTS-PS900	GTS-PS903
Product size (mm)	900×700×1095	1365×700×1095
Refrigerant	R290	R290
Temperature (°C)	+2~+8	+2~+8
Net weight (Kg)	91	124
Net capacity (L)	250	390
Rated power (W)	204	321
Refrigeration type	Static	Static

Product certification



* We have the right to change the product design and configuration without informing customers in advance!



GTS-PS900



GTS-PS903

GN Pans Configurations

GTS-PS900

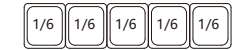

GTS-PS903



Plan View

Front View

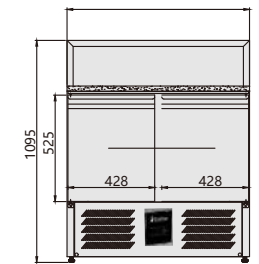

GTS-PS900

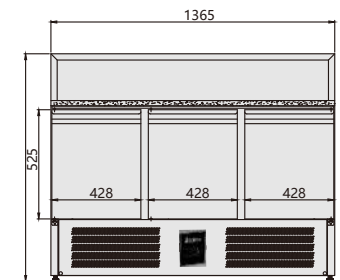

GTS-PS903

Side View

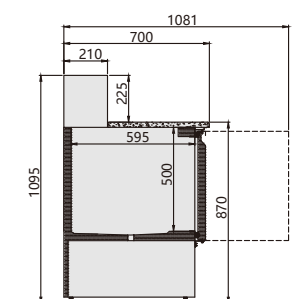

SALADETTE WITH STAINLESS STEEL COVER

Product features

- 304 Stainless steel structure
- GN1/1 adaptable shelves
- Static cooling system
- High density polyurethane insulated structure
- Self-closing door with magnetic gasket
- Easy to clean rounded interior structure
- Adjustable shelves design
- EU branded compressor
- EU branded digital controller
- Automatic defrost system
- Doors are adaptable for drawer assembling
- Adjustable feet or wheels available
- R290 Gas



Product details



1. Europe Brand Digital Controller
2. Polyethylene Cutting Top
3. 10 mm Glass Thickness
4. Adjustable Shelves Design
5. Rounded Edge Corner
6. Optional Divided GN Pan Bars
7. Ventilated refrigeration type

Product parameters

Model	GTS-S438	GTS-S700 S/STOP
Product size (mm)	438×700×865	700×700×865
Refrigerant	R290	R290
Temperature (°C)	+2~+8	+2~+8
Net weight (Kg)	50	55
Net capacity (L)	200	200
Rated power (W)	204	290
Refrigeration type	Ventilated	Ventilated

Product certification



* We have the right to change the product design and configuration without informing customers in advance!



GTS-S438



GTS-S700 S/STOP

GN Pans Configurations

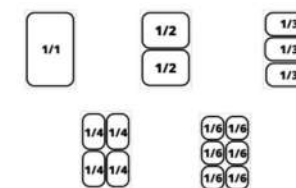

Plan View

Front View

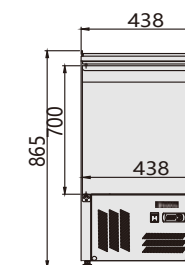

GTS-S438

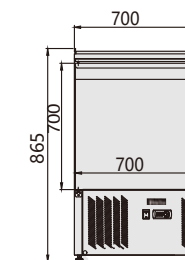

GTS-S700 S/STOP

Side View

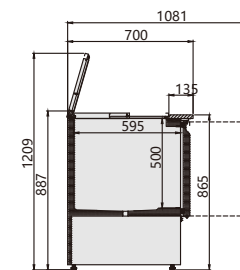

SALADETTE WITH TABLE TOP

Product features

- Open for GN1/6 other GN pans is available
- High density insulation for cooling system
- Static or ventilated system are available
- Stainless steel structure
- GN1/1 shelf size for operation
- Europe brand controller & Europe brand compressor
- Round corner hygiene
- Inner bottom use bend line to drain pipe
- Castor is available
- Top quality cooper pipe built-in
- Led light is available
- Magnetic gasket can be changed without tools
- Door easy to change Drawers or Glass door
- The door can be interchanged by drawers

Product details



1. Europe brand controller
2. Fractional plate design, classified storage, food does not taste
3. SS cover
4. Adjustable shelving
5. Beveled handle design and multiple door seals
6. Stainless steel table

Product parameters

Model	GTS-PS200	GTS-PS300
Product size (mm)	903×700×993	1368×700×993
Refrigerant	R290	R290
Temperature (°C)	+2~+8	+2~+8
Net weight (Kg)	67	91
Net capacity (L)	250	390
Rated power (W)	204	321
Refrigeration type	Static	Static

Product certification



* We have the right to change the product design and configuration without informing customers in advance!



GTS-PS200



GTS-PS300

GN Pans Configurations

GTS-PS200

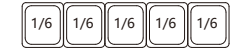

GTS-PS300



Plan View

Front View

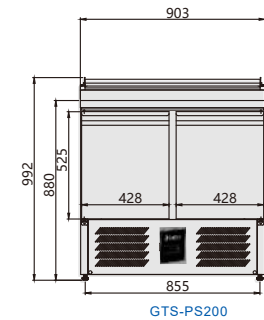

GTS-PS200

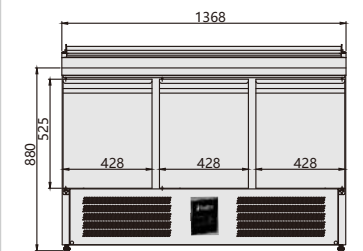

GTS-PS300

Side View

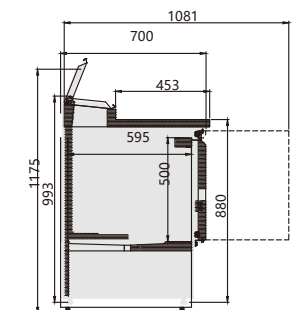

AMERICAN STYLE SALADETTE WITH TABLE TOP

Product features

- Openable fan-shaped basin cover
- Widened chopping board
- Open for GN1/6 other GN pans is available
- High density insulation for cooling system
- Static or ventilated system are available
- GN1/1 shelf size for operation
- Europe brand controller & Europe brand compressor
- Round corner hygiene
- Inner bottom use bend line to drain pipe
- Castor is available
- Top quality cooper pipe built-in
- Led light is available
- Magnetic gasket can be changed without tools
- Door easy to change Drawers or Glass door
- The door can be interchanged by drawers

Product details



1. Europe brand controller
2. Chopping board
3. The fan-shaped basin cover can be opened
4. Adjustable shelving
5. Door handle design
6. GN several plates classified storage, food does not smell

Product parameters

Model	GTS-US900	GTS-US903
Product size (mm)	900×700×1066	1365×700×1066
Refrigerant	R290	R290
Temperature (°C)	+2~+8	+2~+8
Net weight (Kg)	91	124
Net capacity (L)	250	390
Rated power (W)	204	321
Refrigeration type	Static	Static

Product certification



* We have the right to change the product design and configuration without informing customers in advance!



GTS-US900



GTS-US903

GN Pans Configurations

GTS-US900



GTS-US903



Plan View

Front View

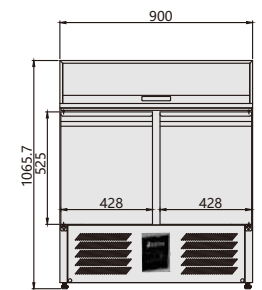

GTS-US900

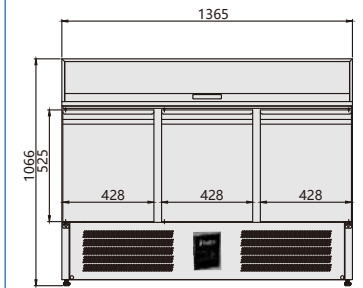

GTS-US903

Side View

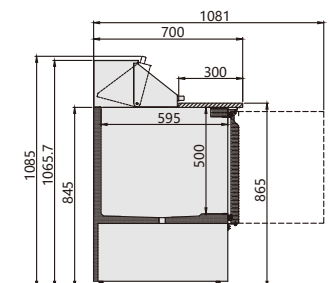

SALADETTE WITH SS TOP

Product features

- Stainless Steel top
- High density insulation for cooling system
- Static or ventilated system are available
- Stainless steel structure
- GN1/1 shelf size for operation
- Europe brand controller & Europe brand compressor
- Round corner hygiene
- Inner bottom use bend line to drain pipe
- Castor is available
- Top quality cooper pipe built-in
- Led light is available
- Magnetic gasket can be changed without tools
- Door easy to change Drawers or Glass door
- The door can interchanged by drawers

Product details



1. Europe brand controller
2. Stainless Steel top
3. Gaskets can be easily to clean and changed
4. Adjustable shelving
5. Door handle design
6. Durable casters for easy movement

Product parameters

Model	GTS-S901 TOP/G	GTS-S901 S/S Top	GTS-S903 S/S Top
Product size (mm)	903×700×880	903×700×880	1368×700×880
Refrigerant	R290	R290	R290
Temperature (°C)	+2~+8	+2~+8	+2~+8
Net weight (Kg)	72	63	86
Net capacity (L)	250	250	390
Rated power (W)	204	204	321
Refrigeration type	Static	Static	Static

Product certification



* We have the right to change the product design and configuration without informing customers in advance!



GTS-S901 S/S Top



GN1/1 shelf size for operation.

Plan View

Side View

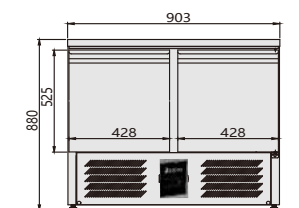

GTS-S901 S/S Top 2×GN1/2

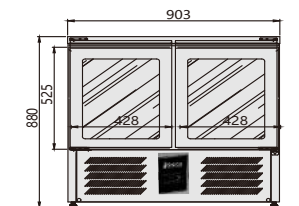

GTS-S901 S/S Top 4×GN1/2

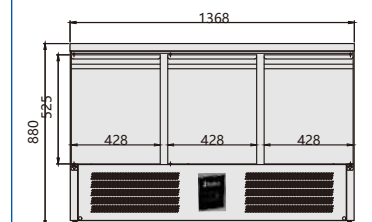

GTS-S903 S/S Top

Side View

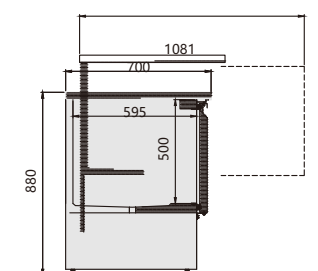

GTS-S901 TOP/G



GTS-S903 S/S Top

SALADETTE WITH SS TOP

Product features

- Stainless Steel top
- High density insulation for cooling system
- Static or ventilated system are available
- Stainless steel structure
- GN1/1 shelf size for operation
- Europe brand controller & Europe brand compressor
- Round corner hygiene
- Inner bottom use bend line to drain pipe
- Castor is available
- Top quality cooper pipe built-in
- Led light is available
- Magnetic gasket can be changed without tools
- Door easy to change Drawers or Glass door
- The door can interchanged by drawers

Product details



1. Europe brand controller
2. Stainless Steel top
3. Gaskets can be easily to clean and changed
4. Adjustable shelving
5. Door handle design
6. Durable casters for easy movement

Product parameters

Model	GTS-S901 S/S Top 2×GN1/2	GTS-S901 S/S Top 4×GN1/2
Product size (mm)	903×700×880	903×700×880
Refrigerant	R290	R290
Temperature (°C)	+2~+8	+2~+8
Net weight (Kg)	110	82
Net capacity (L)	250	250
Rated power (W)	204	204
Refrigeration type	Static	Static

Product certification



* We have the right to change the product design and configuration without informing customers in advance!



GTS-S901 S/S Top 2×GN1/2



GTS-S901 S/S Top 4×GN1/2



Easy to replace into drawers, GN1/1
Open for GN1/1.

Plan View

Front View

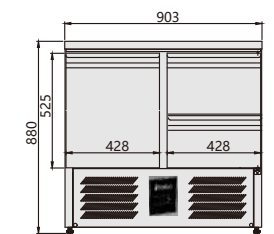

GTS-S901 S/S Top 2×GN1/2

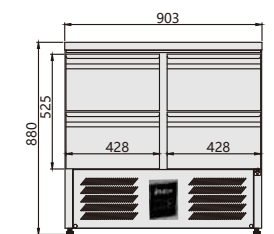

GTS-S901 S/SGTS- Top 4×GN1/2

Side View

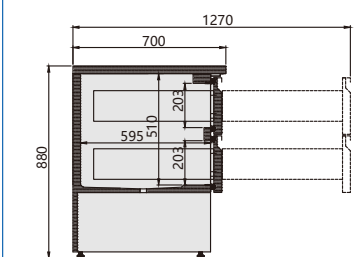

SALADETTE WITH GRANITE TOP

Product features

- Granite top
- High density insulation for cooling system
- Static or ventilated system are available
- Stainless steel structure
- GN1/1 shelf size for operation
- Europe brand controller & Europe brand compressor
- Round corner hygiene
- Inner bottom use bend line to drain pipe
- Castor is available
- Top quality cooper pipe built-in
- Led light is available
- Magnetic gasket can be changed without tools
- Door easy to change Drawers or Glass door
- The door can be interchanged by drawers

Product details

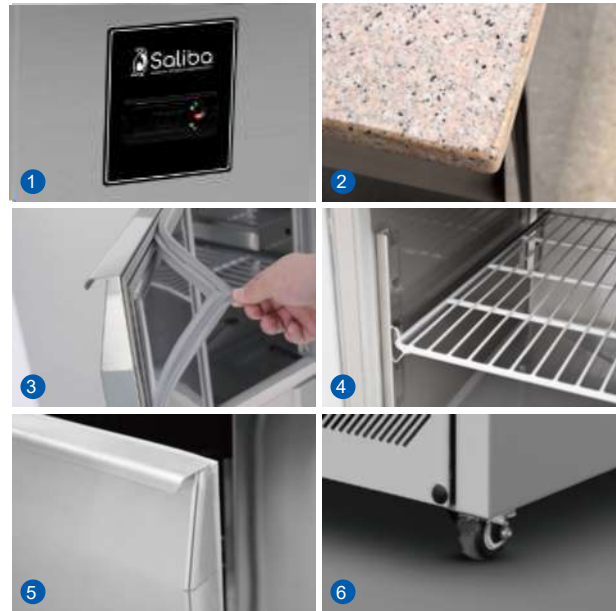

1. Europe brand controller
2. High quality marble countertop
3. Gaskets can be easily to clean and changed
4. Adjustable shelving
5. Door handle design
6. Durable casters for easy movement

Product parameters

Model	GTS-S901 Granite Top	GTS-S903 Granite Top
Product size (mm)	903×700×870	1368×700×870
Refrigerant	R290	R290
Temperature (°C)	+2~+8	+2~+8
Net weight (Kg)	110	156
Net capacity (L)	250	390
Rated power (W)	204	321
Refrigeration type	Static	Static

Product certification



*We have the right to change the product design and configuration without informing customers in advance!



GTS-S901 Granite Top



GTS-S903 Granite Top

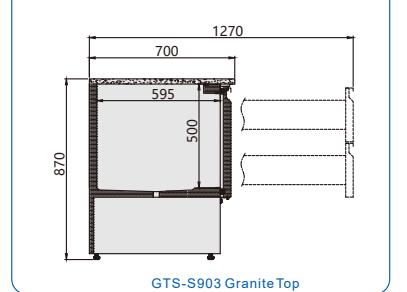
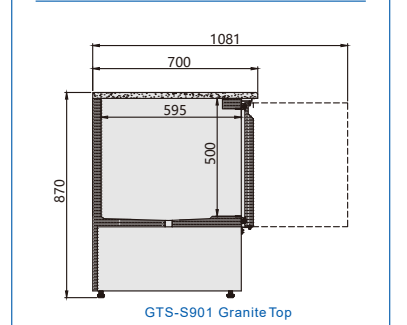
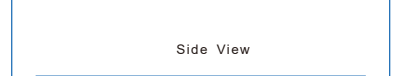
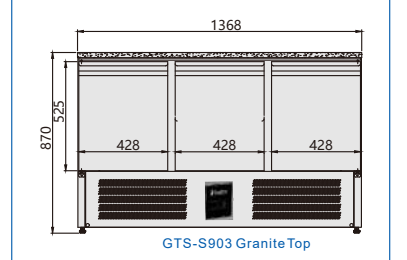
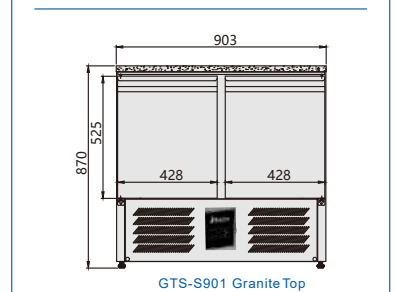

SALADETTE COUNTER TOP (GLASS COVER)

Product features

- 304 Stainless steel structure
- GN1/1 adaptable shelves
- Static cooling system
- High density polyurethane insulated structure
- Self-closing door with magnetic gasket
- Easy to clean rounded interior structure
- Adjustable shelves design
- EU branded compressor
- EU branded digital controller
- Automatic defrost system
- Doors are adaptable for drawer assembling
- Adjustable feet or wheels available
- R290 Gas

Product details



1. Europe Brand Digital Controller
2. Polyethylene Cutting Top
3. 10 mm Glass Thickness
4. Adjustable Shelves Design
5. Rounded Edge Corner
6. Marble Top and GN 1/1 Pans

Product parameters

Model	GTS-LS903	GTS-SW903
Product size (mm)	1365×700×850	1365×700×850
Refrigerant	R290	R290
Temperature (°C)	+2~+8	+2~+8
Net weight (Kg)	132	150
Net capacity (L)	390	390
Rated power (W)	324	321
Refrigeration type	Ventilated	Ventilated

Product certification



* We have the right to change the product design and configuration without informing customers in advance!



GTS-LS903



GTS-SW903

GN Pans Configurations

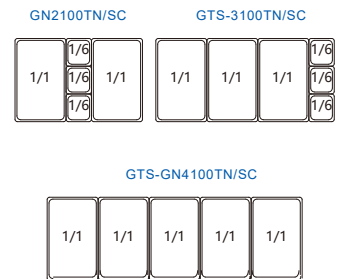

Plan View

Front View

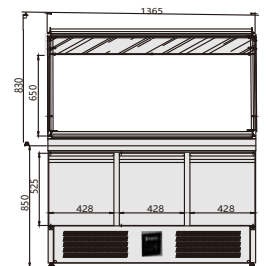

GTS-LS903

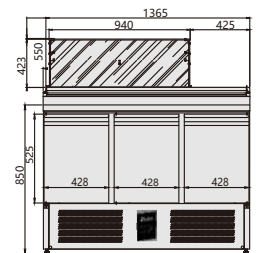

GTS-SW903

Side View

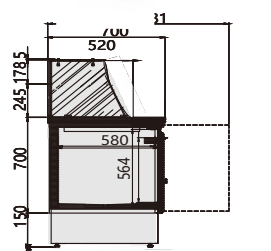
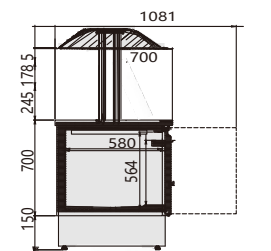

VENTILATED SALAD COUNTER

Product features

- Europe standard GN 1/1 pan designed
- Stainless steel structure
- Ventilated cooling system
- High density insulation body
- Europe brand controller
- European brand compressor
- Smart automatic defrosting
- Interior body with round corner, easy to clean
- Self-closing door with magnetic gaskets
- Adjustable shelving design
- Tempering glass with 8mm thickness
- The depth of the counter can be customized to 60cm,65cm,70cm,75cm,80cm
- The door can interchanged by drawers

Product details



1. Europe brand controller
2. Adjustable shelving design
3. Glass cover, refrigerated and fresh-keeping
4. Round edge counter
5. Europe standard door handle
6. GN several plates classified storage, food does not smell

Product parameters

Model	GTS-GN2100TN/SC	GTS-GN3100TN/SC	GTS-GN4100TN/SC
Product size (mm)	1360×700×1278	1795×700×1278	2230×700×1278
Package size (mm)	1420×740×1060	1845×740×1060	2280×740×1060
Temperature (°C)	+2~+8	+2~+8	+2~+8
Net weight (Kg)	126	138	186
Net capacity (L)	260	400	540
Rated power (W)	320	370	470
Refrigeration type	Ventilated	Ventilated	Ventilated

Product certification



* We have the right to change the product design and configuration without informing customers in advance!



GTS-GN2100TN/SC



GTS-GN3100TN/SC



GTS-GN4100TN/SC

GN Pans Configurations

GN2100TN/SC: 1/1, 1/6, 1/6, 1/6, 1/1

GTS-3100TN/SC: 1/1, 1/1, 1/1, 1/6, 1/6, 1/6

GTS-GN4100TN/SC: 1/1, 1/1, 1/1, 1/1, 1/1

Plan View

Front View

GTS-GN2100TN/SC: 1360 (total), 877 (counter), 461 (cabinet), 423 (height), 850 (depth)

GTS-GN3100TN/SC: 1795 (total), 1242 (counter), 525 (cabinet), 423 (height), 850 (depth)

GTS-GN4100TN/SC: 2230 (total), 1690 (counter), 517 (cabinet), 423 (height), 850 (depth)

SideView

GTS-GN4100TN/SC: 1081 (width), 700 (counter), 245.178.5 (height), 580 (depth), 150 (base)

COCKTAIL STATION CHILLER

Product features

- Double row removable stepped wine tank
- Large capacity ice tank with detachable partition
- Mixer platform with power socket
- Reservoir with faucet
- Table with backrest
- European standard, cabinet and drawer can hold GN1/1 number basins
- Stainless steel structure
- Ventilated cooling system
- High density insulation body
- Europe brand controller
- Europe brand compressor
- Adjustable feet or castor is available

Product details



1. Europe brand controller
2. European standard large capacity drawer
3. Stepped wine tank
4. Mixer platform
5. Europe standard door handle
6. Adjustable feet or castor is available

Product parameters

Model	GTS-GN3100TN-JWJ
Product size (mm)	1795×700×850+100
Refrigerant	R290
Temperature (°C)	-2~+8
Net weight (Kg)	-
Net capacity (L)	-
Rated power (W)	393
Refrigeration type	Ventilated

Product certification



* We have the right to change the product design and configuration without informing customers in advance!



R290 -2~+8°C



Saliba wine mixing table series refrigeration products are a new series of products created with Italian partners over the years.

Plan View

Top View

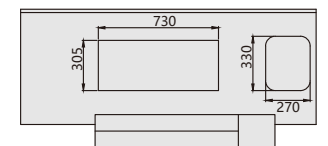

Front View

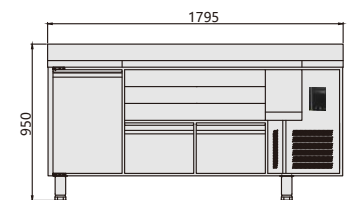

Side View

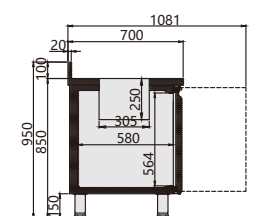

OPEN TOP TABLE SALAD COUNTER

Product features

- Europe standard GN 1/1 pan designed
- Stainless steel structure
- Ventilated cooling system
- High density insulation body
- Europe brand controller
- European brand compressor
- Smart automatic defrosting
- Interior body with round corner, easy to clean
- Self-closing door with magnetic gaskets
- Adjustable shelving design
- Easy to disassemble the unit, convenient for maintenance.
- The depth of the counter can be customized to 60cm,65cm,70cm,75cm,80cm
- The door can interchanged by drawers

Product details



1. UE branded Digital Controller
2. Adjustable shelving design
3. Europe standard GN 1/1 pan designed

Product parameters

Model	GTS-GN2100-W	GTS-GN3100-W	GTS-GN4100-W
Product size (mm)	1360×700×850	1795×700×850	2230×700×850
Package size (mm)	1420×740×910	1845×740×910	2280×740×910
Temperature (°C)	+2~+8	+2~+8	+2~+8
Net weight (Kg)	92	113	134
Net capacity (L)	260	400	540
Rated power (W)	350	360	470
Refrigeration type	Ventilated	Ventilated	Ventilated

Product certification



* We have the right to change the product design and configuration without informing customers in advance!

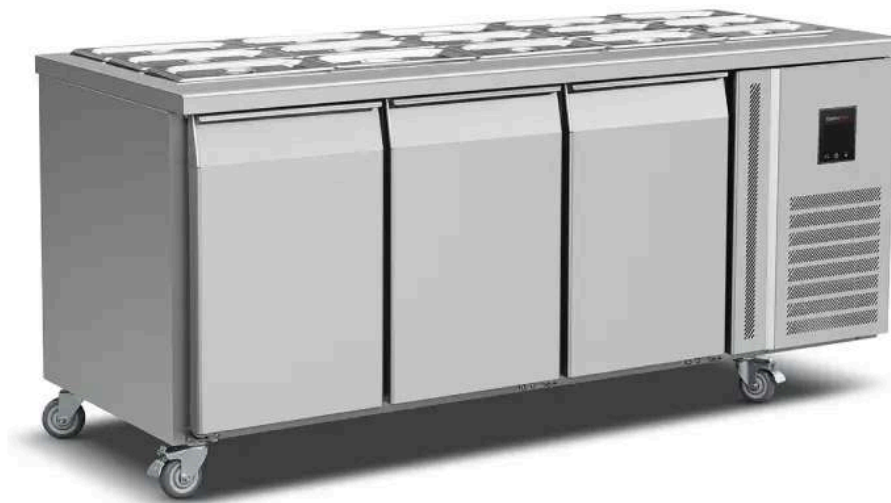

GTS-GN3100-W

GN Pans Configurations

GTS-GN2100-W



GTS-GN3100-W



GTS-GN4100-W

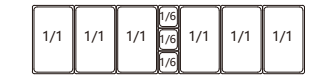

Plan View

Front View

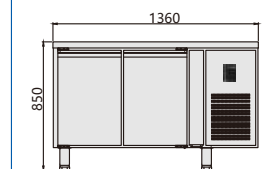

GTS-GN2100-W

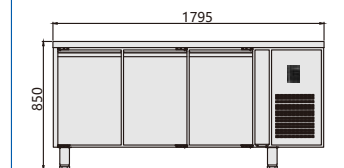

GTS-GN3100-W

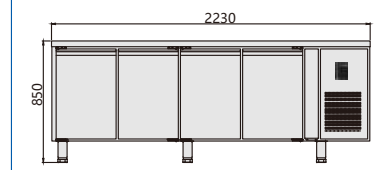

GTS-GN4100-W

Side View

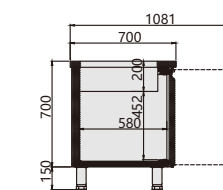



STAINLESS STEEL KITCHEN SERIES

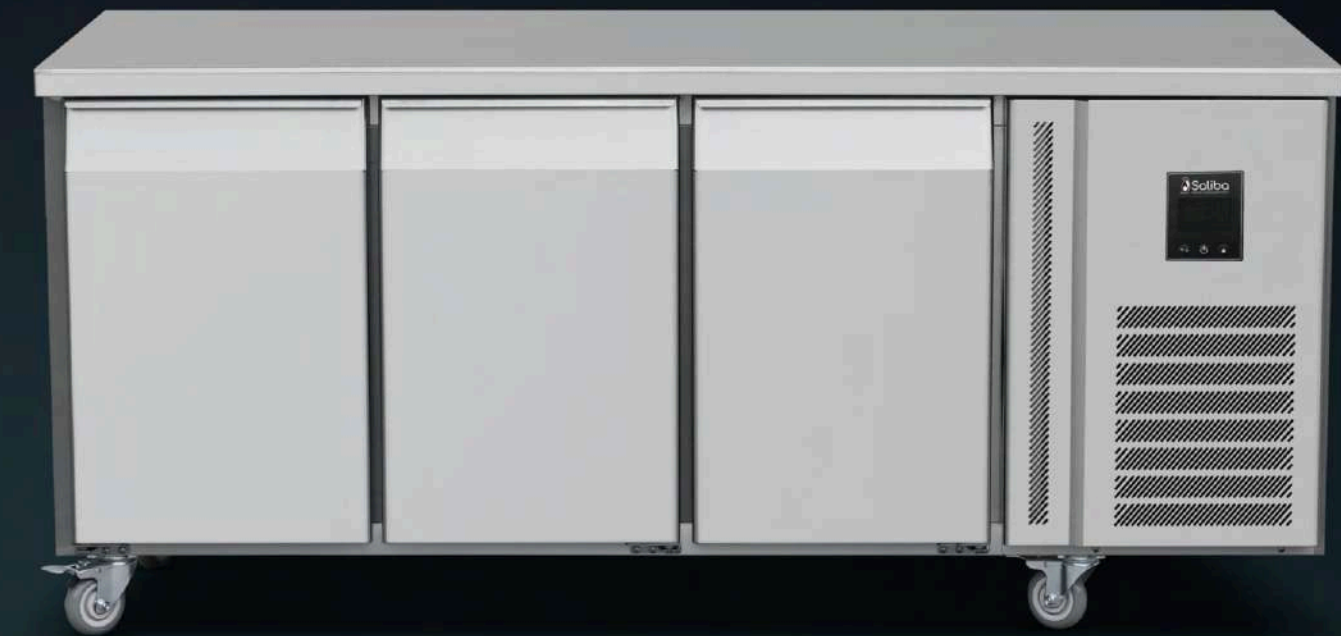

COUNTER CHILLER

Product features

- Europe standard GN 1/1 pan designed
- Stainless steel structure
- Ventilated cooling system
- High density insulation body
- Europe brand controller
- European brand compressor
- Smart automatic defrosting
- Interior body with round corner, easy to clean
- Self-closing door with magnetic gaskets
- Adjustable shelving design
- The depth of the counter can be customized to 60cm,65cm,70cm,75cm,80cm
- The door can be interchanged by drawers

Product details



1. Europe brand controller
2. Adjustable shelving design
3. Gaskets can be easily to clean and changed
4. Round edge counter
5. Porous motor heat dissipation, faster cooling
6. Adjustable feet or castor is available

Product parameters

Model	GTS-GN1100TN	GTS-GN2100TN	GTS-GN3100TN	GTS-GN4100TN
Product size (mm)	925×700×850	1360×700×850	1795×700×850	2230×700×850
Package size (mm)	985×740×910	1420×740×910	1845×740×910	2280×740×910
Temperature (°C)	+2~+8	+2~+8	+2~+8	+2~+8
Net weight (Kg)	75	92	113	134
Net capacity (L)	140	260	400	540
Rated power (W)	350	350	360	470
Refrigeration type	Ventilated	Ventilated	Ventilated	Ventilated

Product certification



* We have the right to change the product design and configuration without informing customers in advance!



GTS-GN1100TN



GTS-GN2100TN



GTS-GN3100TN



GTS-GN4100TN

R290 TN: +2~+8°C

Optional

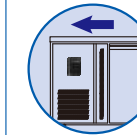

Left unit

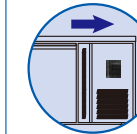

Right unit



Water basin



Doors can be easily change to be drawers.

Plan View

Front View

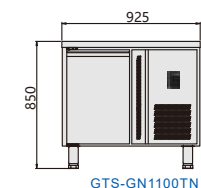

GTS-GN1100TN

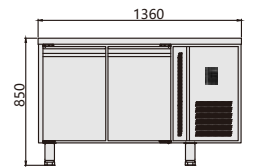

GTS-GN2100TN

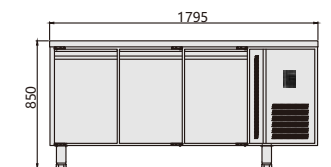

GTS-GN3100TN

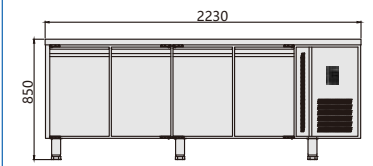

GTS-GN4100TN

Side View

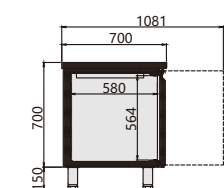

COUNTER FREEZER

Product features

- Europe standard GN 1/1 pan designed
- Stainless steel structure
- Ventilated cooling system
- High density insulation body
- Europe brand controller
- European brand compressor
- Smart automatic defrosting
- Freezer models are added heating element in doorframe, keep no fog around doorframe
- Interior body with round corner, easy to clean
- Self-closing door with magnetic gaskets
- Adjustable shelving design
- The depth of the counter can be customized to 60cm,65cm,70cm,75cm,80cm
- The door can be interchanged by drawers

Product details



1. Europe brand controller
2. Adjustable shelving design
3. Gaskets can be easily to clean and changed
4. Round edge counter
5. Porous motor heat dissipation, faster cooling
6. Adjustable feet or castor is available

Product parameters

Model	GTS-GN1100BT	GTS-GN2100BT	GTS-GN3100BT	GTS-GN4100BT
Product size (mm)	925×700×850	1360×700×850	1795×700×850	2230×700×850
Package size (mm)	985×740×910	1420×740×910	1845×740×910	2280×740×910
Temperature (°C)	-15~-20	-15~-20	-15~-20	-15~-20
Net weight (Kg)	87	104	114	138
Net capacity (L)	140	260	400	540
Rated power (W)	588	588	560	798
Refrigeration type	Ventilated	Ventilated	Ventilated	Ventilated

Product certification



* We have the right to change the product design and configuration without informing customers in advance!



GTS-GN1100BT



GTS-GN2100BT



GTS-GN3100BT



GTS-GN4100BT

R290 BT: -15~-20°C

Optional

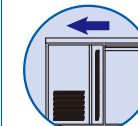

Left unit

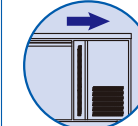

Right unit



Water basin



Doors can be easily change to be drawers.

Plan View

Front View

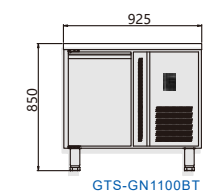

GTS-GN1100BT

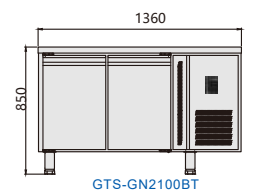

GTS-GN2100BT

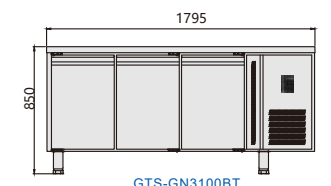

GTS-GN3100BT

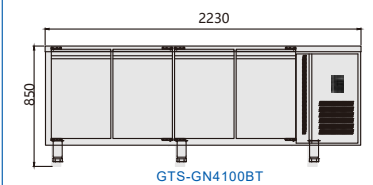

GTS-GN4100BT

Side View

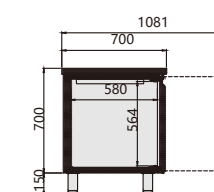

GLASS DOOR COUNTER CHILLER

Product features

- Europe standard GN 1/1 pan designed
- Stainless steel structure
- Ventilated cooling system
- High density insulation body
- Europe brand controller
- European brand compressor
- Smart automatic defrosting
- Heat re-insulating & Insulating glass
- Interior body with round corner, easy to clean
- Self-closing door with magnetic gaskets
- Adjustable shelving design
- The depth of the counter can be customized to 60cm, 65cm, 70cm, 75cm, 80cm
- The door can be interchanged by drawers

Product details



1. Europe brand controller
2. Adjustable shelving design
3. Gaskets can be easily to clean and changed
4. Heat re-insulating & Insulating glass
5. Porous motor heat dissipation, faster cooling
6. Adjustable feet or castor is available

Product parameters

Model	GTS-GN2100TN/G	GTS-GN3100TN/G	GTSGN4100TN/G
Product size (mm)	1360×700×850	1795×700×850	2230×700×850
Package size (mm)	1420×740×910	1845×740×910	2280×740×910
Temperature (°C)	+2~+8	+2~+8	+2~+8
Net weight (Kg)	94	117	140
Net capacity (L)	260	400	540
Rated power (W)	350	370	481
Refrigeration type	Ventilated	Ventilated	Ventilated

Product certification



* We have the right to change the product design and configuration without informing customers in advance!



R290 TN: +2~+8°C



GTS-GN2100TN/G



GTS-GN3100TN/G



GTS-GN4100TN/G

Optional

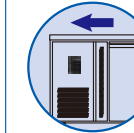

Left unit

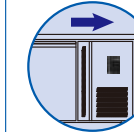

Right unit



Water basin



Round edge counter.

Plan View

Front View

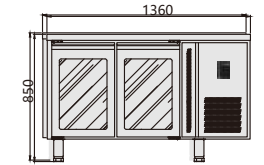

GTS-GN2100TN/G

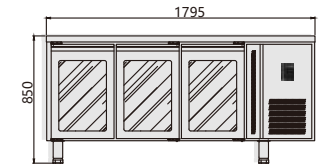

GTS-GN3100TN/G

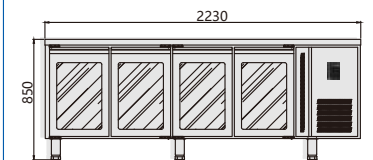

GTS-GN4100TN/G

Side View

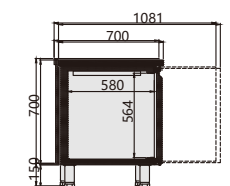

COUNTER CHILLER WITH DRAWERS

Product features

- Europe standard GN 1/1 pan designed
- Stainless steel structure
- Ventilated cooling system
- High density insulation body
- Europe brand controller
- European brand compressor
- Smart automatic defrosting
- Freezer models are added heating element in doorframe, keep no fog around doorframe
- Interior body with round corner, easy to clean
- Self-closing door with magnetic gaskets
- Adjustable shelving design
- The depth of the counter can be customized to 60cm,65cm,70cm,75cm,80cm
- The door can interchanged by drawers

Product details



1. Europe brand controller
2. Doors can be easily change to be drawers
3. Europe standard door handle
4. Adjustable shelving design
5. Gaskets can be easily to clean and changed
6. Adjustable feet or castor is available

Product parameters

Model	GTS-GN2120TN	GTS-GN2130TN	GTS-GN2140TN	GTS-GN2160TN
Product size (mm)	1360×700×850	1360×700×850	1360×700×850	1360×700×850
Package size (mm)	1420×740×910	1420×740×910	1420×740×910	1420×740×910
Temperature (°C)	+2~+8	+2~+8	+2~+8	+2~+8
Net weight (Kg)	99	101	127	134
Net capacity (L)	260	260	260	260
Rated power (W)	350	350	350	350
Refrigeration type	Ventilated	Ventilated	Ventilated	Ventilated

Product certification



* We have the right to change the product design and configuration without informing customers in advance!



GTS-GN2120TN



GTS-GN2130TN



GTS-2140TN



GTS-GN2160TN

R290 TN: +2~+8°C

Optional

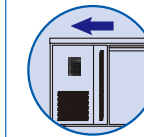

Left unit

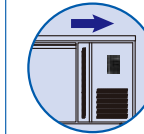

Right unit



Water basin

Plan View

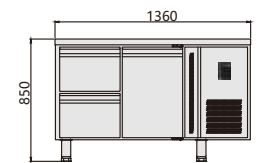

1360

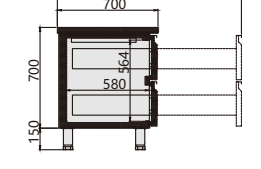

GTS-GN2120TN

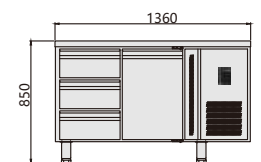

1360

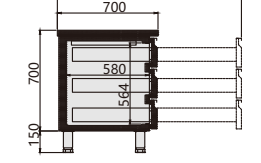

GTS-GN2130TN

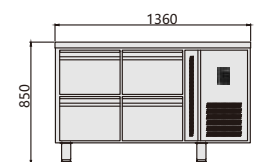

1360

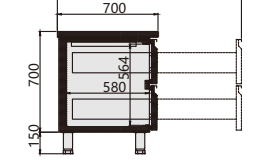

GTS-GN2140TN

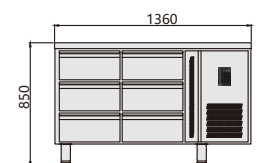

1360

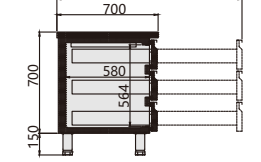

GTS-GN2160TN

COUNTER CHILLER WITH DRAWERS

Product features

- Europe standard GN 1/1 pan designed
- Stainless steel structure
- Ventilated cooling system
- High density insulation body
- Europe brand controller
- European brand compressor
- Smart automatic defrosting
- Freezer models are added heating element in doorframe, keep no fog around doorframe
- Interior body with round corner, easy to clean
- Self-closing door with magnetic gaskets
- Adjustable shelving design
- The depth of the counter can be customized to 60cm,65cm,70cm,75cm,80cm
- The door can interchanged by drawers

Product details



1. The drawer can hold standard gn1 / 1 copies
2. Interior body with round corner, easy to clean
3. Round edge counter

Product parameters

Model	GTS-GN3120TN	GTS-GN3130TN	GTS-GN3140TN	GTS-GN3180TN
Product size (mm)	1795×700×850	1795×700×850	1795×700×850	1795×700×850
Package size (mm)	1845×740×910	1845×740×910	1845×740×910	1845×740×910
Temperature (°C)	+2~+8	+2~+8	+2~+8	+2~+8
Net weight (Kg)	120	122	127	134
Net capacity (L)	400	400	400	400
Rated power (W)	370	370	370	370
Refrigeration type	Ventilated	Ventilated	Ventilated	Ventilated

Product certification



* We have the right to change the product design and configuration without informing customers in advance!



GTS-GN3120TN



GTS-GN3130TN



GTS-GN3140TN



GTS-GN3180TN

R290 TN: +2~+8°C

Optional

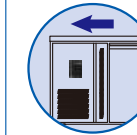

Left unit

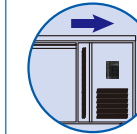

Right unit



Water basin

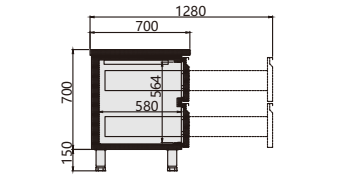
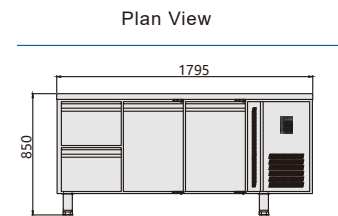

GTS-GN3120TN

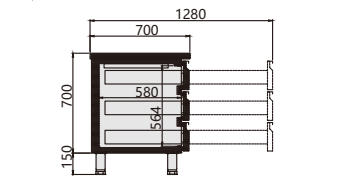
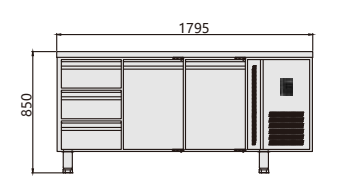

GTS-GN3130TN

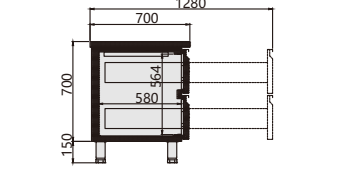
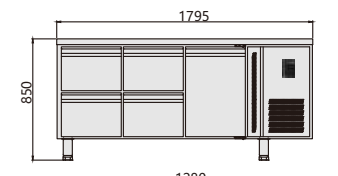

GTS-GN3140TN

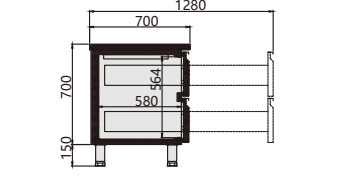
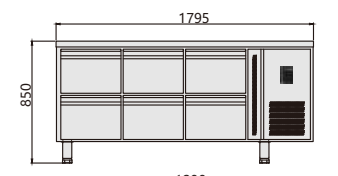

GTS-GN3160TN

COUNTER CHILLER WITHDRAWERS

Product features

- Europe standard GN 1/1 pan designed
- Stainless steel structure
- Ventilated cooling system
- High density insulation body
- Europe brand controller
- European brand compressor
- Smart automatic defrosting
- Freezer models are added heating element in doorframe, keep no fog around doorframe
- Interior body with round corner, easy to clean
- Self-closing door with magnetic gaskets
- Adjustable shelving design
- The depth of the counter can be customized to 60cm,65cm,70cm,75cm,80cm
- The door can interchanged by drawers

Product details



1. The drawer can hold standard gn1 / 1 copies
2. Interior body with round corner, easy to clean
3. Round edge counter

Product parameters

Model	GTS-GN4120TN	GTS-GN4130TN	GTS-GN4140TN	GTS-GN4180TN
Product size (mm)	2230×700×850	2230×700×850	2230×700×850	2230×700×850
Package size (mm)	2280×740×910	2280×740×910	2280×740×910	2280×740×910
Temperature (°C)	-15~-20	-15~-20	-15~-20	-15~-20
Net weight (Kg)	155	158	171	192
Net capacity (L)	540	540	540	540
Rated power (W)	470	798	798	798
Refrigeration type	Ventilated	Ventilated	Ventilated	Ventilated

Product certification



* We have the right to change the product design and configuration without informing customers in advance!



GTS-GN4120TN



GTS-GN4130TN



GTS-GN4140TN



GTS-GN4180TN

R290 TN: +2~+8°C

- Optional
- Left unit
 - Right unit
 - Water basin

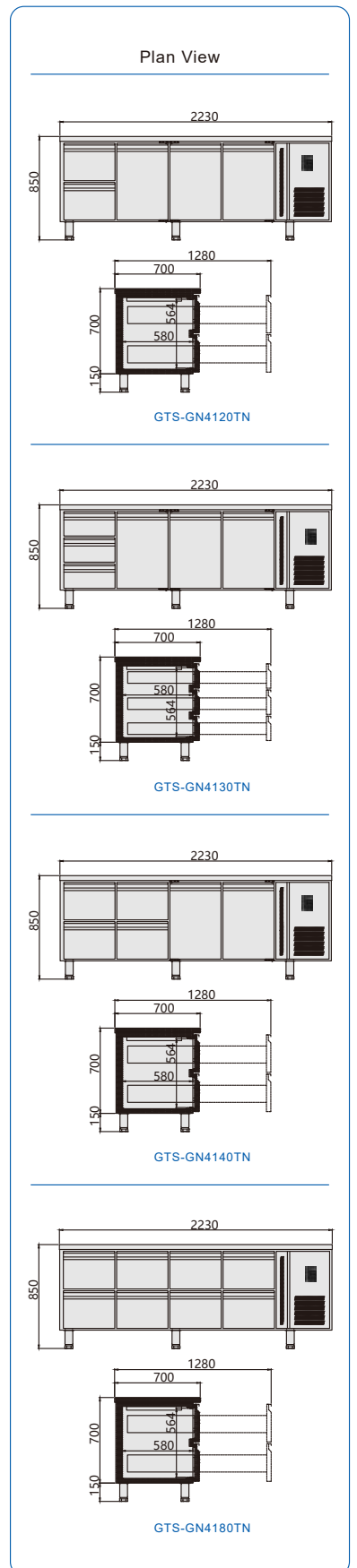

COUNTER FREEZER WITH DRAWERS

Product features

- Europe standard GN 1/1 pan designed
- Stainless steel structure
- Ventilated cooling system
- High density insulation body
- Europe brand controller
- European brand compressor
- Smart automatic defrosting
- Freezer models are added heating element in doorframe, keep no fog around doorframe
- Interior body with round corner, easy to clean
- Self-closing door with magnetic gaskets
- Adjustable shelving design
- The depth of the counter can be customized to 60cm,65cm,70cm,75cm,80cm
- The door can interchanged by drawers

Product details



1. Europe brand compressor
2. Adjustable shelving design
3. Doors can be easily change to be drawers

Product parameters

Model	GTS-GN2120BT	GTS-GN2130BT	GTS-GN2140BT	GTS-GN2160BT
Product size (mm)	1360×700×850	1360×700×850	1360×700×850	1360×700×850
Package size (mm)	1420×740×910	1420×740×910	1420×740×910	1420×740×910
Temperature (°C)	-15~-20	-15~-20	-15~-20	-15~-20
Net weight (Kg)	105	105	112	113
Net capacity (L)	260	260	260	260
Rated power (W)	588	588	588	588
Refrigeration type	Ventilated	Ventilated	Ventilated	Ventilated

Product certification



* We have the right to change the product design and configuration without informing customers in advance!



GTS-GN2120BT



GTS-GN2130BT



GTS-GN2140BT



GTS-GN2160BT

R290 BT: -15~-20°C

Optional

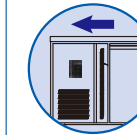

Left unit

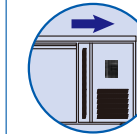

Right unit



Water basin

Plan View

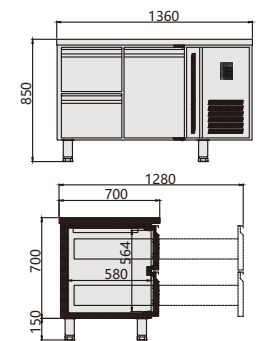

GTS-GN2120BT

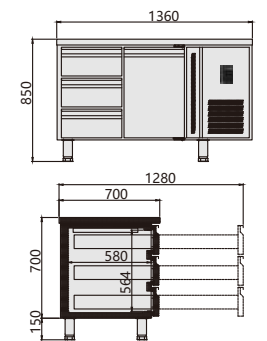

GTS-GN2130BT

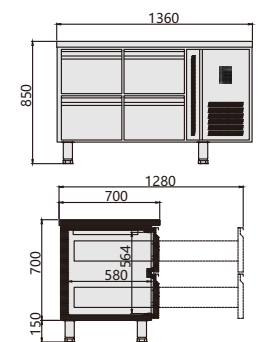

GTS-GN2140BT

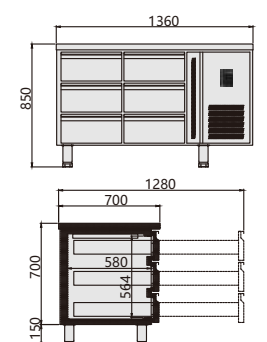

GTS-GN2160BT

COUNTER FREEZER WITH DRAWERS

Product features

- Europe standard GN 1/1 pan designed
- Stainless steel structure
- Ventilated cooling system
- High density insulation body
- Europe brand controller
- European brand compressor
- Smart automatic defrosting
- Freezer mordels are added heating element in doorframe, keep no fog around doorframe
- Interior body with round corner, easy to clean
- Self-closing door with magnetic gaskets
- Adjustable shelving design
- The depth of the counter can be customized to 60cm,65cm,70cm,75cm,80cm
- The door can interchanged by drawers

Product details



1. Gaskets can be easily to clean and changed
2. Adjustable feet or castor is available
3. Europe standard door handle

Product parameters

Model	GTS-GN3120BT	GTS-GN3130BT	GTS-GN3140BT	GTS-GN3160BT
Product size (mm)	1795×700×850	1795×700×850	1795×700×850	1795×700×850
Package size (mm)	1845×740×910	1845×740×910	1845×740×910	1845×740×910
Temperature (°C)	-15~-20	-15~-20	-15~-20	-15~-20
Net weight (Kg)	124	124	130	131
Net capacity (L)	400	400	400	400
Rated power (W)	560	560	560	560
Refrigeration type	Ventilated	Ventilated	Ventilated	Ventilated

Product certification



* We have the right to change the product design and configuration without informing customers in advance!



GTS-GN3120BT



GTS-GN3130BT



GTS-GN3140BT



GTS-GN3160BT

R290 BT: -15~-20°C

Optional

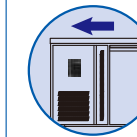

Left unit

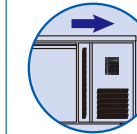

Right unit



Water basin

Plan View

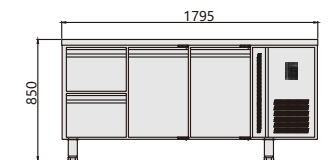

GTS-GN3120BT

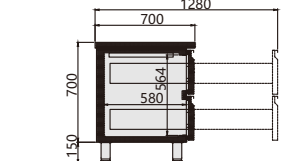

GTS-GN3120BT

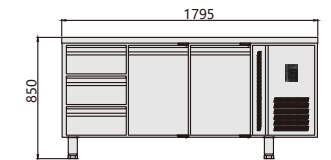

GTS-GN3130BT

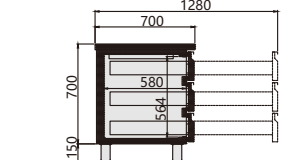

GTS-GN3130BT

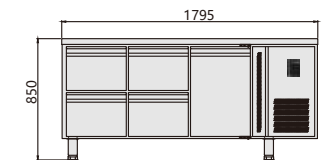

GTS-GN3140BT

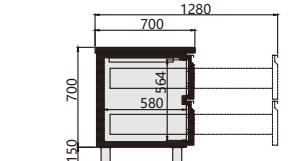

GTS-GN3140BT

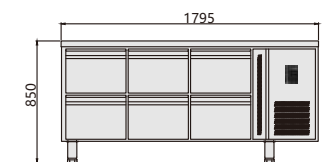

GTS-GN3160BT

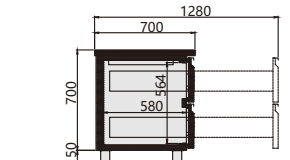

GTS-GN3160BT

COUNTER FREEZER WITHDRAWERS

Product features

- Europe standard GN 1/1 pan designed
- Stainless steel structure
- Ventilated cooling system
- High density insulation body
- Europe brand controller
- European brand compressor
- Smart automatic defrosting
- Freezer mordels are added heating element in doorframe, keep no fog around doorframe
- Interior body with round corner, easy to clean
- Self-closing door with magnetic gaskets
- Adjustable shelving design
- The depth of the counter can be customized to 60cm,65cm,70cm,75cm,80cm
- The door can interchanged by drawers

Product details



1. The drawer can hold standard gn1 / 1 copies
2. Interior body with round corner, easy to clean
3. Round edge counter

Product parameters

Model	GTS-GN4120BT	GTS-GN4130BT	GTS-GN4140BT	GTS-GN4180BT
Product size (mm)	2230×700×850	2230×700×850	2230×700×850	2230×700×850
Package size (mm)	2280×740×910	2280×740×910	2280×740×910	2280×740×910
Temperature (°C)	-15~-20	-15~-20	-15~-20	-15~-20
Net weight (Kg)	158	162	175	198
Net capacity (L)	540	540	540	540
Rated power (W)	798	798	798	798
Refrigeration type	Ventilated	Ventilated	Ventilated	Ventilated

Product certification



* We have the right to change the product design and configuration without informing customers in advance!



GTS-GN4120BT



GTS-GN4130BT



GTS-GN4140BT



GTS-GN4180BT

R290 BT: -15~-20°C

Optional

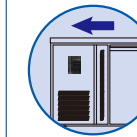

Left unit

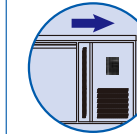

Right unit



Water basin

Plan View

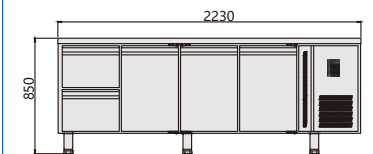

GTS-GN4120BT

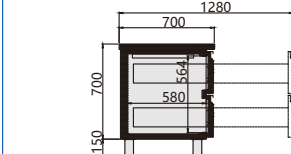

GTS-GN4130BT

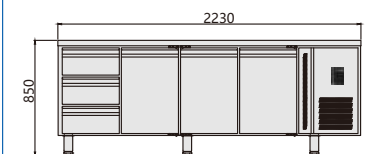

GTS-GN4140BT

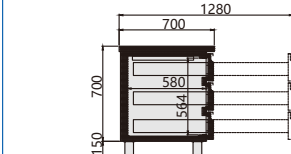

GTS-GN4180BT

650MM COUNTER

Product features

- Europe standard GN 1/1 pan designed
- Stainless steel structure
- Ventilated cooling system
- High density insulation body
- Europe brand controller
- European brand compressor
- Smart automatic defrosting
- Interior body with round corner, easy to clean
- Self-closing door with magnetic gaskets
- Adjustable shelving design
- The depth of the counter can be customized to 60cm,65cm,70cm,75cm,80cm
- The door can be interchanged by drawers

Product details



1. Europe brand controller
2. Adjustable shelving design
3. Gaskets can be easily to clean and changed
4. Round edge counter
5. Europe standard door handle
6. Adjustable feet or castor is available

Product parameters

Model	GTS-UNGN2100TN	GTS-UNGN3100TN	GTS-UNGN4100TN
Product size (mm)	1600×700×650	2000×700×650	2400×700×650
Package size (mm)	1660×740×710	2060×740×710	2460×740×710
Temperature (°C)	+2~+8	+2~+8	+2~+8
Net weight (Kg)	78	105	132
Net capacity (L)	200	320	450
Rated power (W)	210	393	470
Refrigeration type	Ventilated	Ventilated	Ventilated

Product certification



* We have the right to change the product design and configuration without informing customers in advance!



GTS-UNGN2100TN



GTS-UNGN3100TN



GTS-UNGN4100TN

R290 TN: +2~+8°C

Optional

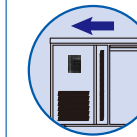

Left unit

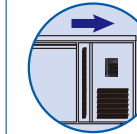

Right unit



Doors can be easily change to be drawers.

Plan View

Front View

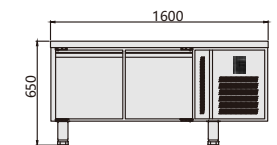

GTS-UNGN2100TN

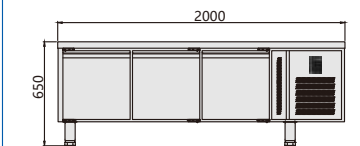

GTS-UNGN3100TN

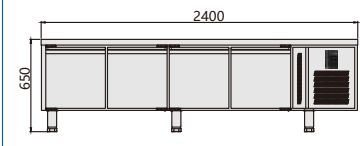

GTS-UNGN4100TN

Side View

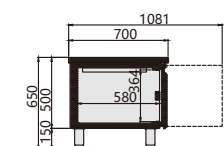

650MM COUNTER WITH DRAWER

Product features

- Europe standard GN 1/1 pan designed
- Stainless steel structure
- Ventilated cooling system
- High density insulation body
- Europe brand controller
- European brand compressor
- Smart automatic defrosting
- Interior body with round corner, easy to clean
- Self-closing door with magnetic gaskets
- Adjustable shelving design
- The depth of the counter can be customized to 60cm,65cm,70cm,75cm,80cm
- The door can interchanged by drawers

Product details



1. Europe brand controller
2. Adjustable shelving design
3. Gaskets can be easily to clean and changed
4. Round edge counter
5. Europe standard door handle
6. Adjustable feet or castor is available

Product parameters

Model	GTS-UNGN2140TN	GTS-UNGN3160TN	GTS-UNGN4180TN
Product size (mm)	1600×700×650	2000×700×650	2400×700×650
Package size (mm)	1660×740×710	2060×740×710	2460×740×710
Temperature (°C)	+2~+8	+2~+8	+2~+8
Net weight (Kg)	104	126	170
Net capacity (L)	200	320	450
Rated power (W)	210	393	470
Refrigeration type	Ventilated	Ventilated	Ventilated

Product certification



* We have the right to change the product design and configuration without informing customers in advance!

R290 TN: +2~+8°C



GTS-UNGN2140TN



GTS-UNGN3160TN



GTS-UNGN4180TN

Drawer door type



Type A drawer door Type B drawer door

Optional

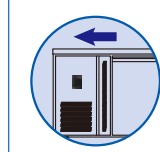

Left unit

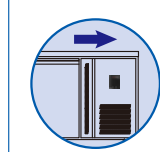

Right unit

Plan View

Front View

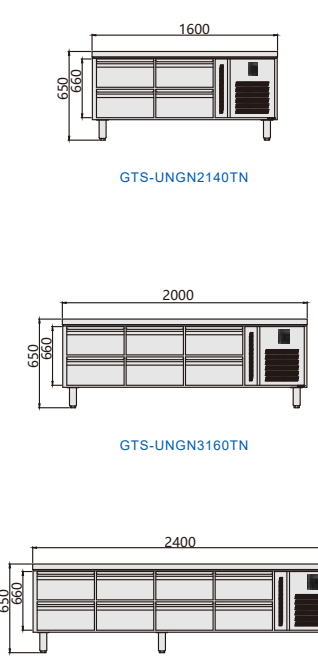

GTS-UNGN2140TN

GTS-UNGN3160TN

GTS-UNGN4180TN

Side View

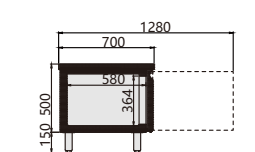

CHEF DRAWER

Product features

- Refrigeration and freezing can be switched freely
- European standard large capacity drawer, which can hold 2/1 copies of pots, with a maximum depth of 150mm
- It can be stacked for use, and can be combined with refrigeration and freezing freely- Stainless steel structure
- Stainless steel structure
- High density insulation body
- Europe brand controller
- European brand compressor
- Refrigeration intelligent automatic defrosting
- With magnetic door seal

Product details



1. Europe brand controller
2. European standard large capacity drawer
3. It can be stacked up and down
4. Stainless steel structure
5. Door handle design
6. Cooling holes

Product parameters

Model	GTS-CDF1	GTS-CDGTS-F2
Product size (mm)	1100×670×455	1100×670×834.5
Package size (mm)	1140×710×610	1140×710×990
Temperature (°C)	+2~+8/ -15~-20	+2~+8/ -15~-20
Net weight (Kg)	61	122
Net capacity (L)	78	156
Rated power (W)	255	510
Refrigeration type	Ventilated	Ventilated

Product certification



* We have the right to change the product design and configuration without informing customers in advance!

R290 +2~+8°C -15~-20°C



GTS-CDF1



GTS-CDF2

Plan View

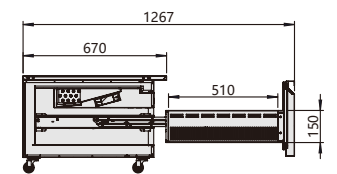
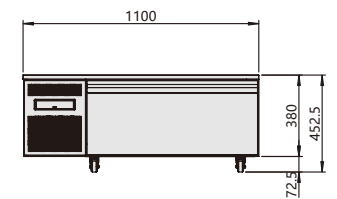

GTS-CDF1

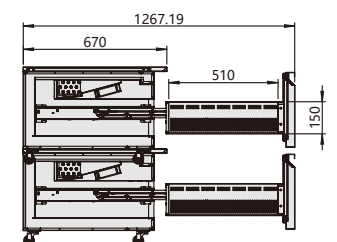
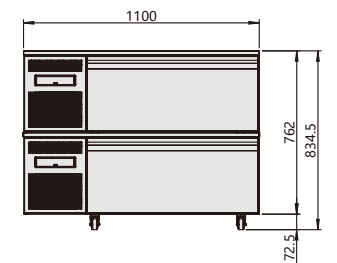

GTS-CDF2



UPRIGHT CHILLER / FREEZER SERIES (STAINLESS STEEL DOOR)



GTS-HKC1150 GTS-SNACK301 GTS-SNACK400 GTS-SNACK650 GTS-GN650 GTS-GN1410

UPRIGHT CHILLER / FREEZER SERIES (GLASS DOOR)



GTS-HKC1150/G GTS-SNACK301/G GTS-SNACK400/G GTS-SNACK650/G GTS-GN650/G GTS-GN1410/G

SINGLE DOOR UPRIGHT CHILLER / FREEZER (LOWER)

Product features

- Stainless steel structure
- Ventilated system
- High density insulation body
- Europe brand digital controller
- Europe brand compressor
- Automatic defrosting
- Self-closing door with magnetic gaskets
- Adjustable shelving
- Glass door is available
- Adjustable feet or castor is available
- Led light is available
- Freezer mode are added heating element in doorframe, keep no fog around doorframe

Product details



1. Europe brand controller
2. Led light is available
3. Adjustable shelving
4. Fan fast cycle refrigeration
5. Stainless steel structure
6. Glass door is available

Product parameters

Model	GTS-SNACK301TN	GTS-SNACK301BT
Product size (mm)	498×690(40)×2040	498×690(40)×2040
Refrigerant	R290	R290
Temperature (°C)	+2~+8	-18~-22
Net weight (Kg)	98	98
Net capacity (L)	300	300
Rated power (W)	340	490
Refrigeration type	Ventilated	Ventilated

Product certification



* We have the right to change the product design and configuration without informing customers in advance!

STAINLES STEEL KITCHEN SERIES

R290 TN: +2~+8°C
R290 BT: -18~-22°C



Put standard gn 1 / 1 copies on the tray.

Plan View

Front View

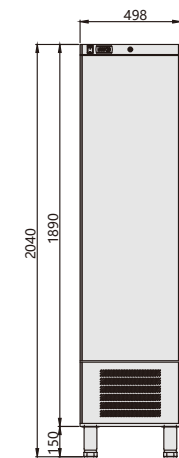

Side View

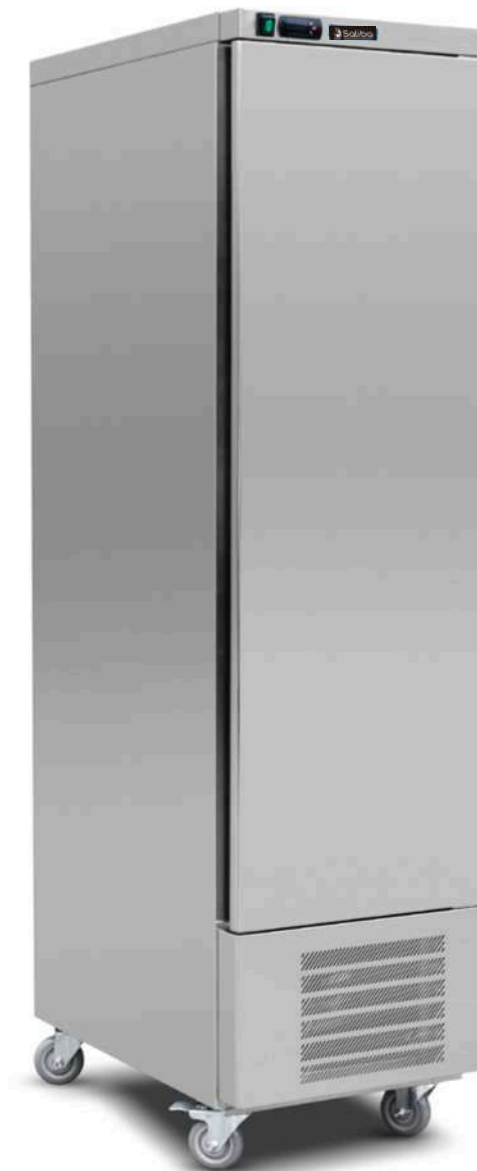
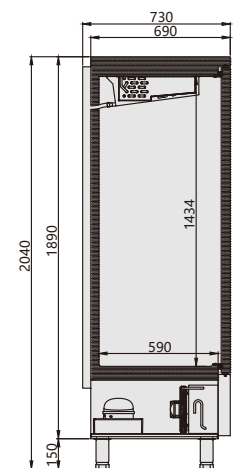

SINGLE DOOR UPRIGHT CHILLER / FREEZER (Lower)

Product features

- Stainless steel structure
- Static / Ventilated system
- High density insulation body
- Europe brand digital controller
- Europe brand compressor
- Automatic defrosting
- Self-closing door with magnetic gaskets
- Adjustable shelving
- Glass door is available
- Adjustable feet or castor is available
- Led light is available
- Freezer mode are added heating element in doorframe, keep no fog around doorframe

Product details



1. Europe brand controller
2. Led light is available
3. Adjustable shelving
4. Door locks can be equipped
5. Stainless steel structure
6. Glass door is available

Product parameters

Model	GTS-SNACK400TN	GTS-SNACK400STN	GTS-SNACK400BT	GTS-SNACK400SBT
Product size (mm)	660×690×2010	660×690×2010	660×690×2010	660×690×2010
Refrigerant	R290	R290	R290	R290
Temperature (°C)	+2~+8	+2~+8	-18~-22	-18~-22
Net weight (Kg)	97	97	104	104
Net capacity (L)	450	450	450	450
Rated power (W)	316	316	534	534
Refrigeration type	Ventilated	Static	Ventilated	Static

Product certification



* We have the right to change the product design and configuration without informing customers in advance!

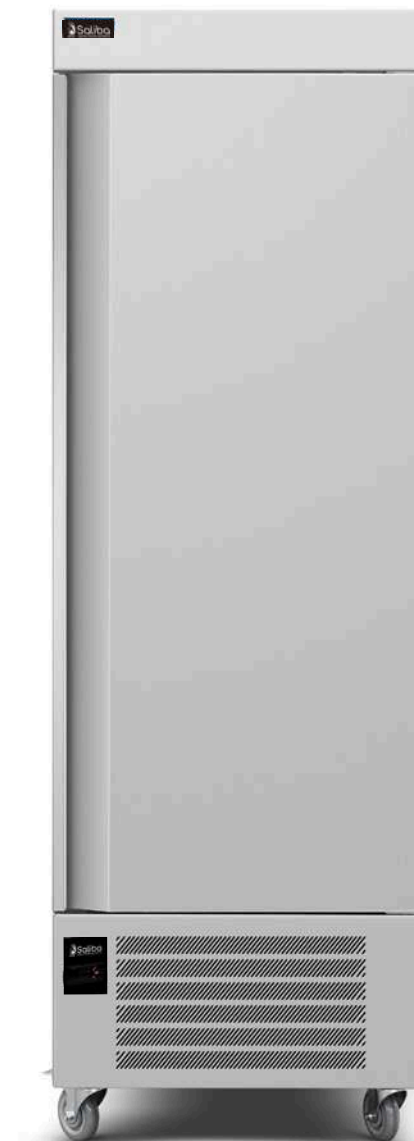

R290 TN: +2~+8°C
R290 BT: -18~-22°C

Plan View

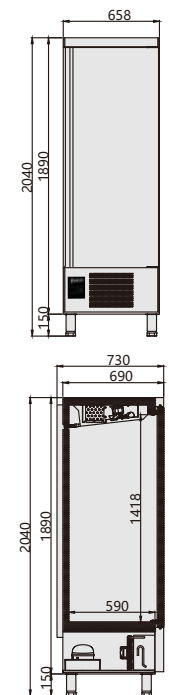

GTS-SNACK400TN GTS-SNACK400BT

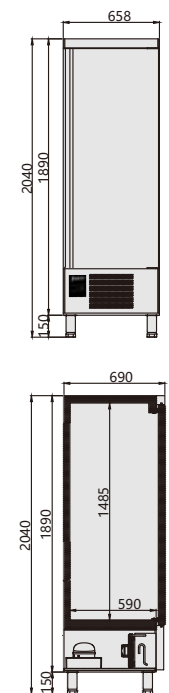

GTS-SNACK400STN GTS-SNACK400SBT

SINGLE DOOR UPRIGHT CHILLER / FREEZER (Upper)

Product features

- Stainless steel structure
- Ventilated system
- High density insulation body
- Europe brand digital controller
- Europe brand compressor
- Automatic defrosting
- Self-closing door with magnetic gaskets
- Adjustable shelving
- Glass door is available
- Adjustable feet or castor is available
- Led light is available
- Freezer mode are added heating element in doorframe, keep no fog around doorframe

Product details



1. Europe brand controller
2. Led light is available
3. Adjustable shelving
4. Door locks can be equipped
5. Stainless steel structure
6. Glass door is available

Product parameters

Model	GTS-GN300TN	GTS-GN600TN	GTS-GN650TN	GTS-GN300BT	GTS-GN600BT	GTS-GN650BT
Product size(mm)	498×690×2040	660×790×2040	740×830×2040	498×690×2040	660×790×2040	740×830×2040
Refrigerant	R290	R290	R290	R290	R290	R290
Temperature (°C)	+2~+8	+2~+8	+2~+8	-18~-22	-18~-22	-18~-22
Net weight (Kg)	98	104	118	98	107	122
Net capacity (L)	300	530	580	300	530	580
Rated power (W)	340	340	369	490	490	552
Refrigeration type	Ventilated	Ventilated	Ventilated	Ventilated	Ventilated	Ventilated

Product certification



*We have the right to change the product design and configuration without informing customers in advance!

- R290 TN: +2~+8°C
- R290 BT: -18~-22°C

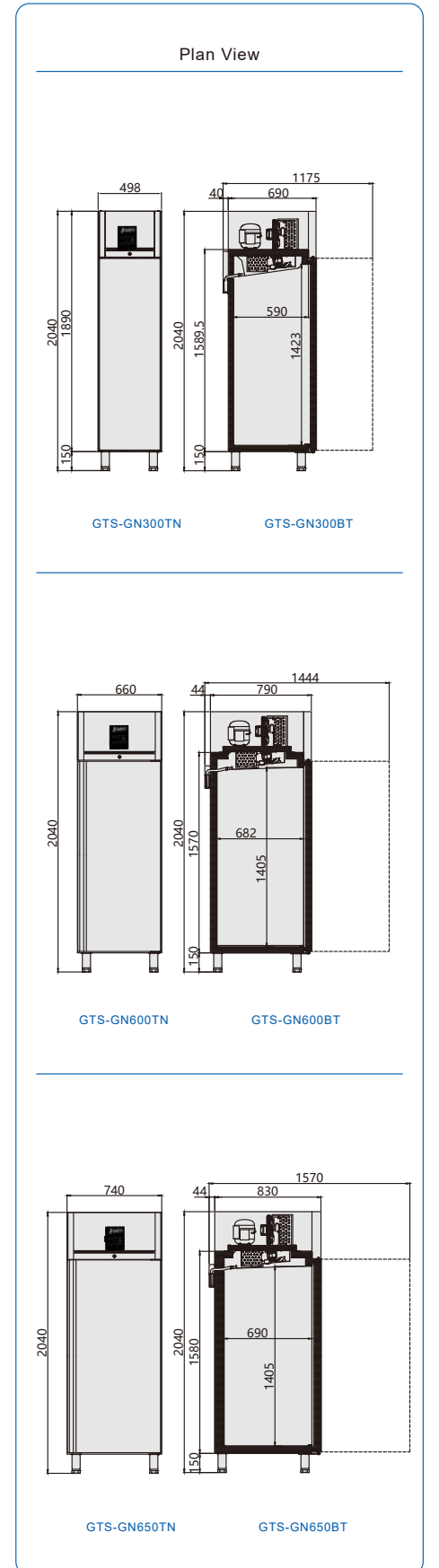

SINGLE DOOR UPRIGHT CHILLER/ FREEZER (-40°C)

Product features

- -40 °C ultralow temperature
- With heated glass door
- LED lighting inside
- Stainless steel structure
- Ventilated system
- High density insulation body
- Europe brand digital controller
- Europe brand compressor
- Automatic defrosting
- Self-closing door with magnetic gaskets
- Adjustable shelving
- Adjustable feet or castor is available
- Freezer mode are added heating element in doorframe, keep no fog around doorframe

Product details



1. Europe brand controller
2. With heated glass door
3. Adjustable shelving
4. Door locks can be equipped
5. Door control switch
6. LED lighting

Product parameters

Model	GTS-GN650BT/G(-40°C)
Product size (mm)	740×830×2040
Refrigerant	R290
Temperature (°C)	-35 ~ -40
Net weight (Kg)	150
Net capacity (L)	580
Rated power (W)	1100
Refrigeration type	Ventilated

Product certification



*We have the right to change the product design and configuration without informing customers in advance!



R290 BT: -35~-40°C



-35 °C to -40 °C to achieve deep freezing effect and maximize the freshness of marine fish and other food materials.

Plan View

Front View

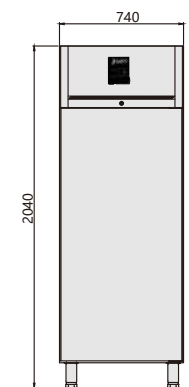

Side View

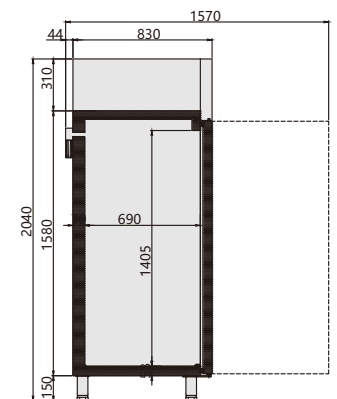

DOUBLE DOOR UPRIGHT CHILLER/ FREEZER

Product features

- Stainless steel structure
- Ventilated system
- High density insulation body
- Europe brand digital controller
- Europe brand compressor
- Automatic defrosting
- Self-closing door with magnetic gaskets
- Adjustable shelving
- Glass door is available
- Adjustable feet or castor is available
- Led light is available
- Freezer mode are added heating element in doorframe, keep no fog around doorframe

Product details



1. Europe brand controller
2. Easy to disassemble the unit and facilitate maintenance
3. Adjustable shelving
4. Door locks can be equipped
5. Stainless steel structure
6. Glass door is available

Product parameters

Model	GTS-GN1200TN	GTS-GN1410TN	GTS-GN1200BT	GTS-GN1410BT
Product size (mm)	1340×800×2040	1480×830×2040	1340×800×2040	1480×830×2040
Refrigerant	R290	R290	R290	R290
Temperature (°C)	+2~+8	+2~+8	-18~-22	-18~-22
Net weight (Kg)	181	184	194	197
Net capacity (L)	1150	1285	1150	1285
Rated power (W)	400	412	909	920
Refrigeration type	Ventilated	Ventilated	Ventilated	Ventilated

Product certification



* We have the right to change the product design and configuration without informing customers in advance!

R290 TN: +2~+8°C
R290 BT: -18~-22°C

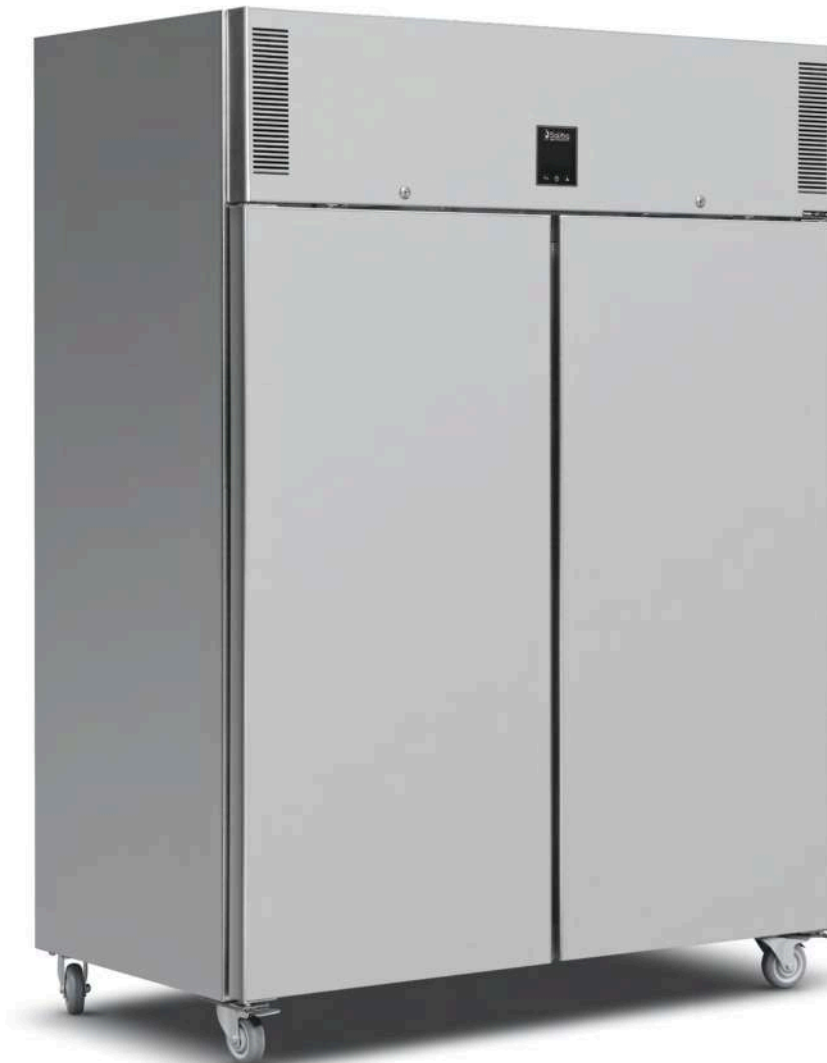

Plan View

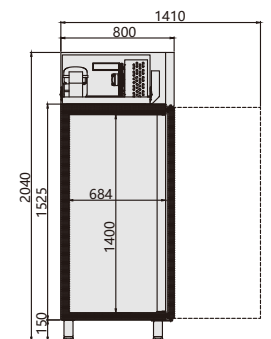
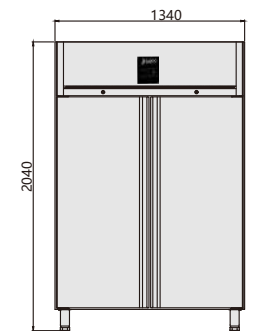

GTS-GN1200TN

GTS-GN1200BT

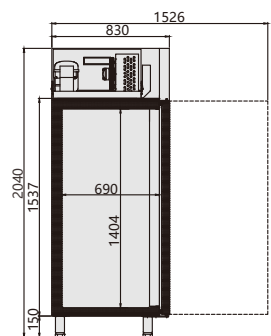
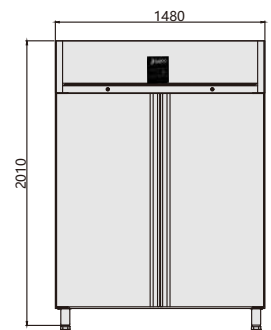

GTS-GN1410TN

GTS-GN1410BT

THREE DOOR UPRIGHT CHILLER / FREEZER

Product features

- Stainless steel structure
- Ventilated system
- High density insulation body
- Europe brand digital controller
- Europe brand compressor
- Automatic defrosting
- Self-closing door with magnetic gaskets
- Adjustable shelving
- Glass door is available
- Adjustable feet or castor is available
- Led light is available
- Freezer mode are added heating element in doorframe ,keep no fog around doorframe

Product details



1. Europe brand controller
2. Fan fast cycle refrigeration
3. Adjustable shelving design
4. Door locks can be equipped
5. Door lamp control switch
6. LED lighting

Product parameters

Model	GTS-GN1800TN	GTS-GN1800BT
Product size (mm)	2010×800×2040	2010×800×2040
Refrigerant	R290	R290
Temperature (°C)	+2~+8	-18~-22
Net weight (Kg)	227	268
Net capacity (L)	1813	1813
Rated power (W)	660	1380
Refrigeration type	Ventilated	Ventilated

Product certification



* We have the right to change the product design and configuration without informing customers in advance!

R290 TN: +2~+8°C
R290 BT: -18~-22°C



Glass door is available.



Plan View

Front View

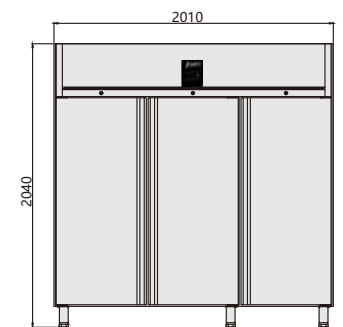

Vertical View

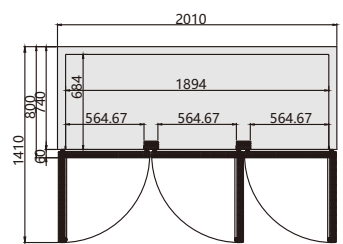

Side View

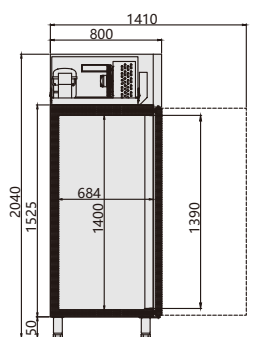

UPPER AND LOWER DOOR UPRIGHT CHILLER / FREEZER

Product features

- Stainless steel structure
- Ventilated system
- High density insulation body
- Europe brand digital controller
- Europe brand compressor
- Automatic defrosting
- Self-closing door with magnetic gaskets
- Adjustable shelving
- Glass door is available
- Adjustable feet or castor is available
- Led light is available
- Freezer mode are added heating element in doorframe , keep no fog around doorframe

Product details



1. Europe brand controller
2. Led light is available
3. Adjustable shelving
4. Door locks can be equipped
5. Stainless steel structure
6. Glass door is available

Product parameters

Model	GTS-GN600TN/D	GTS-GN650TN/D	GTS-GN600BT/D	GTS-GN650BT/D
Product size (mm)	660×790×2040	740×830×2040	660×790×2040	740×830×2040
Refrigerant	R290	R290	R290	R290
Temperature (°C)	+2~+8	+2~+8	-18~-22	-18~-22
Net weight (Kg)	104	119	107	122
Net capacity (L)	530	580	530	580
Rated power (W)	360	310	490	722
Refrigeration type	Ventilated	Ventilated	Ventilated	Ventilated

Product certification



* We have the right to change the product design and configuration without informing customers in advance!

R290 TN: +2~+8°C
R290 BT: -18~-22°C

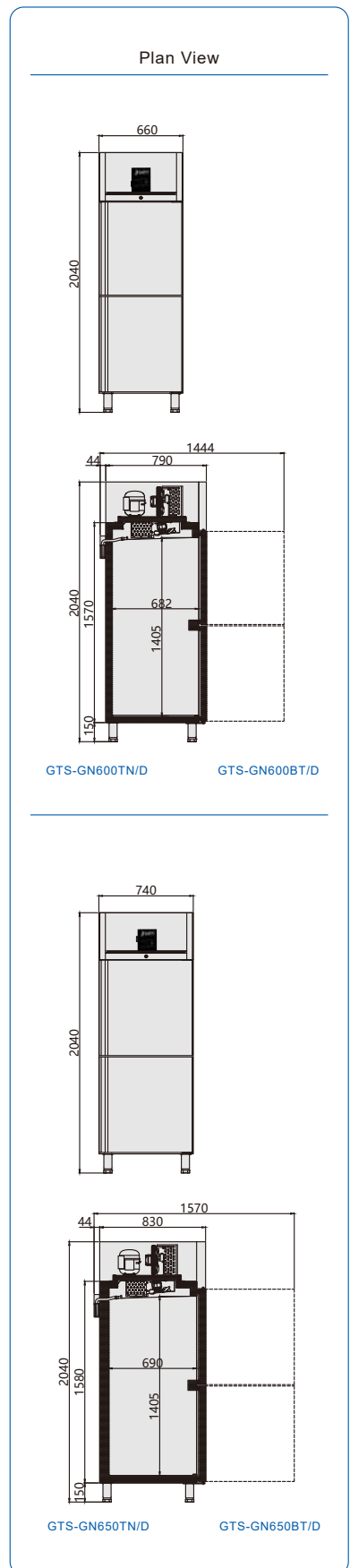

FOUR DOOR UPRIGHT CHILLER / FREEZER

Product features

- Stainless steel structure
- Ventilated system
- High density insulation body
- Europe brand digital controller
- Europe brand compressor
- Automatic defrosting
- Self-closing door with magnetic gaskets
- Adjustable shelving
- Glass door is available
- Adjustable feet or castor is available
- Led light is available
- Freezer mode are added heating element in doorframe, keep no fog around doorframe

Product details



1. Europe brand controller
2. Easy to disassemble the unit and facilitate maintenance
3. Adjustable shelving
4. Door locks can be equipped
5. Stainless steel structure
6. Glass door is available

Product parameters

Model	GTS-GN1200TN/D	GTS-GN1410TN/D	GTS-GN1200BT/D	GTS-GN1410BT/D
Product size (mm)	1340×800×2040	1480×830×2040	1340×800×2040	1480×830×2040
Refrigerant	R290	R290	R290	R290
Temperature (°C)	+2~+8	+2~+8	-18~-22	-18~-22
Net weight (Kg)	181	194	194	210
Net capacity (L)	1150	1285	1150	1285
Rated power (W)	440	412	960	920
Refrigeration type	Ventilated	Ventilated	Ventilated	Ventilated

Product certification



* We have the right to change the product design and configuration without informing customers in advance!

R290 TN: +2~+8°C
R290 BT: -18~-22°C

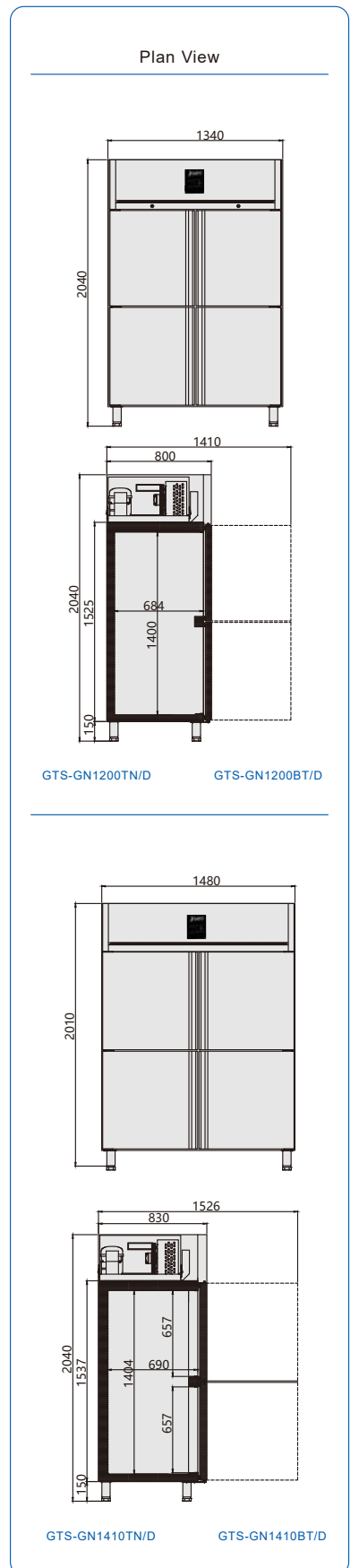

SIX DOOR UPRIGHT CHILLER / FREEZER

Product features

- Stainless steel structure
- Ventilated system
- High density insulation body
- Europe brand digital controller
- Europe brand compressor
- Automatic defrosting
- Self-closing door with magnetic gaskets
- Adjustable shelving
- Glass door is available
- Adjustable feet or castor is available
- Led light is available
- Freezer mode are added heating element in doorframe ,keep no fog around doorframe

Product details

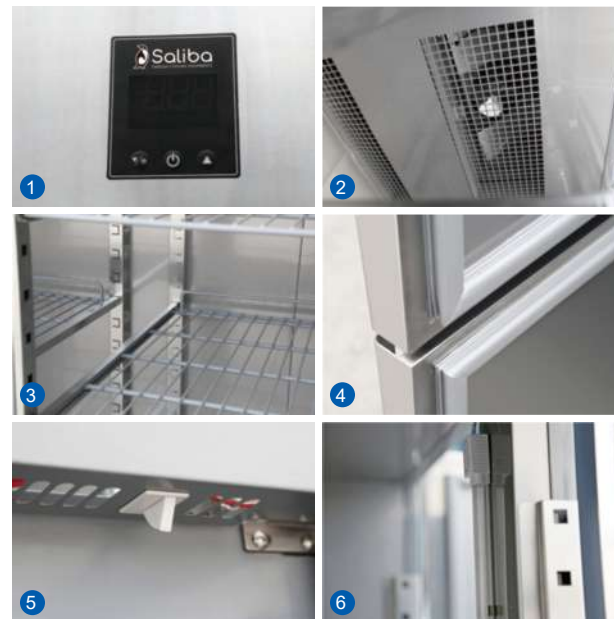

1. Europe brand controller
2. Fan fast cycle refrigeration
3. Adjustable shelving design
4. With magnetic door seal
5. Door lamp control switch
6. LED lighting

Product parameters

Model	GTS-GN1800TN-D	GTS-GN1800BT-D
Product size (mm)	2010×800×2040	2010×800×2040
Refrigerant	R290	R290
Temperature (°C)	+2~+8	-18~-22
Net weight (Kg)	230	271
Net capacity (L)	1813	1813
Rated power (W)	660	1380
Refrigeration type	Ventilated	Ventilated

Product certification



* We have the right to change the product design and configuration without informing customers in advance!

R290 TN: +2~+8°C
R290 BT: -18~-22°C



Glass door is available.



Plan View

Front View

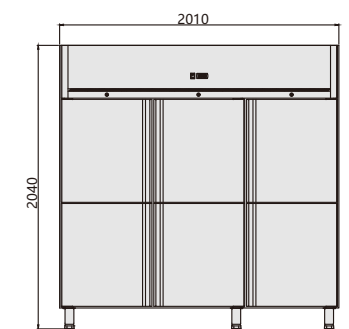

Vertical View

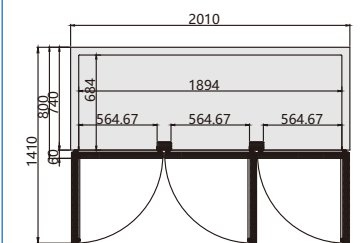

Side View

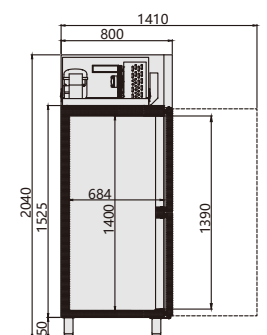

SINGLE GLASS DOOR UPRIGHT CHILLER / FREEZER

Product features

- Stainless steel structure
- Ventilated system
- High density insulation body
- Europe brand digital controller
- Europe brand compressor
- Automatic defrosting
- Self-closing door with magnetic gaskets
- Adjustable shelving
- Stainless steel door is available
- Adjustable feet or castor is available
- Led light is available
- Freezer mode are added heating element in doorframe, keep no fog around doorframe

Product details



1. Europe brand controller
2. Led light is available
3. Adjustable shelving
4. Door locks can be equipped
5. Stainless steel door is available
6. Adjustable feet or castor is available

Product parameters

Model	GTS-GN600TN/G	GTS-GN650TN/G	GTS-GN600BT/G	GTS-GN650BT/G
Product size (mm)	660×790×2040	740×830×2040	660×790×2040	740×830×2040
Refrigerant	R290	R290	R290	R290
Temperature (°C)	+2~+8	+2~+8	-18~-22	-18~-22
Net weight (Kg)	105	130	120	159
Net capacity (L)	530	580	530	580
Rated power (W)	490	460	490	722
Refrigeration type	Ventilated	Ventilated	Ventilated	Ventilated

Product certification



* We have the right to change the product design and configuration without informing customers in advance!



R290 TN: +2~+8°C
R290 BT: -18~-22°C



Plan View

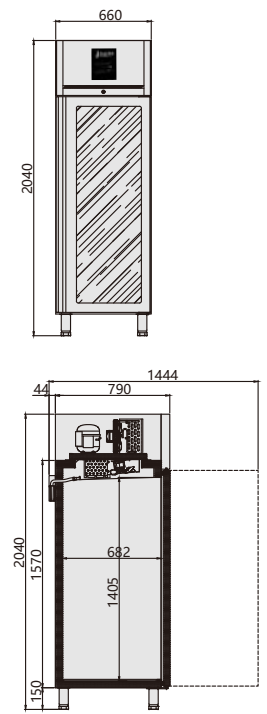

GTS-GN600TN/G GTS-GN600BT/G

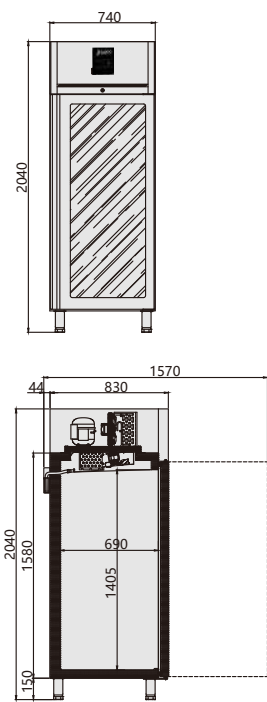

GTS-GN650TN/G GTS-GN650BT/G

DOUBLE GLASS DOOR UPRIGHT CHILLER / FREEZER

Product features

- Stainless steel structure
- Ventilated system
- High density insulation body
- Europe brand digital controller
- Europe brand compressor
- Automatic defrosting
- Self-closing door with magnetic gaskets
- Adjustable shelving
- Stainless steel door is available
- Adjustable feet or castor is available
- Led light is available
- Freezer mode are added heating element in doorframe, keep no fog around doorframe

Product details



1. Europe brand controller
2. Led light is available
3. Adjustable shelving
4. Door locks can be equipped
5. Easy to disassemble the unit and facilitate maintenance
6. Adjustable feet or castor is available

Product parameters

Model	GTS-GN1200TN/G	GTS-GN1410TN/G	GTS-GN1200BT/G	GTS-GN1410BT/G
Product size (mm)	1340×800×2040	1480×830×2040	1340×800×2040	1480×830×2040
Refrigerant	R290	R290	R290	R290
Temperature (°C)	+2~+8	+2~+8	-18~-22	-18~-22
Net weight (Kg)	201	212	214	271
Net capacity (L)	1150	1285	1150	1285
Rated power (W)	412	412	960	920
Refrigeration type	Ventilated	Ventilated	Ventilated	Ventilated

Product certification



* We have the right to change the product design and configuration without informing customers in advance!



R290 TN: +2~+8°C
R290 BT: -18~-22°C



Plan View

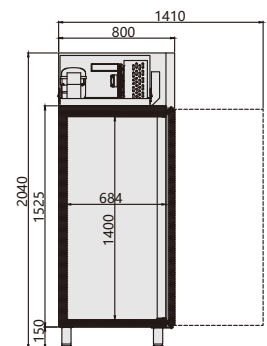
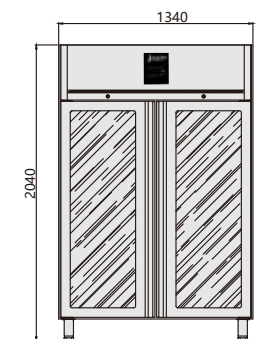

GTS-GN1200TN/G GTS-GN1200BT/G

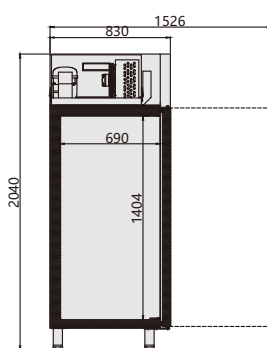
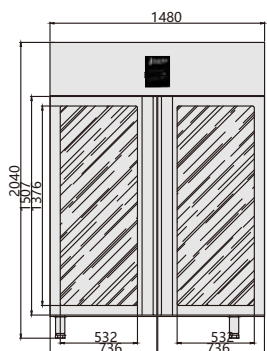

GTS-GN1410TN/G GTS-GN1410BT/G

COMBINED TEMPERATURE

Product features

- Stainless steel structure
- Ventilated system
- High density insulation body
- Europe brand digital controller
- Europe brand compressor
- Automatic defrosting
- Self-closing door with magnetic gaskets
- Adjustable shelving
- Glass door is available
- Adjustable feet or castor is available
- Led light is available
- Freezer mode are added heating element in doorframe, keep no fog around doorframe

Product details



1. Europe brand controller
2. Led light is available
3. Adjustable shelving
4. Door locks can be equipped
5. Stainless steel structure
6. Glass door is available

Product parameters

Model	GTS-GN600DT/D	GTS-GN650DT/D
Product size (mm)	660×790×2040	740×830×2040
Refrigerant	R290	R290
Temperature (°C)	+2 ~ +8 / -18 ~ -22	+2 ~ +8 / -18 ~ -22
Net weight (Kg)	137	147
Net capacity (L)	580	580
Rated power (W)	TN 250; BT 580	TN 260; BT 590
Refrigeration type	Ventilated	Ventilated

Product certification



* We have the right to change the product design and configuration without informing customers in advance!

R290 +2~+8 -18~-22°C



Plan View

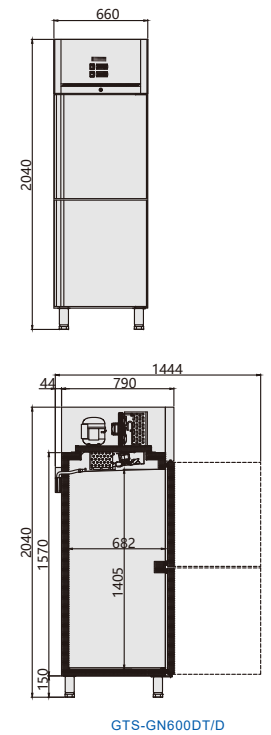

GTS-GN600DT/D

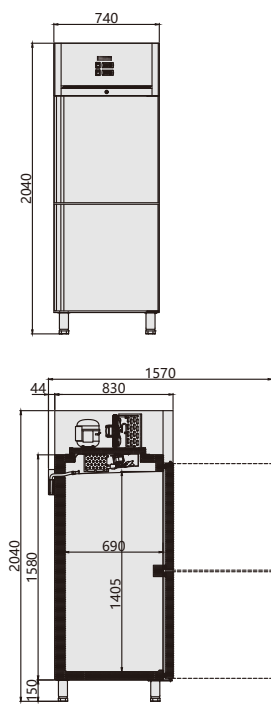

GTS-GN650DT/D

COMBINED TEMPERATURE

Product features

- Stainless steel structure
- Ventilated system
- High density insulation body
- Europe brand digital controller
- Europe brand compressor
- Automatic defrosting
- Self-closing door with magnetic gaskets
- Adjustable shelving
- Glass door is available
- Adjustable feet or castor is available
- Led light is available
- Freezer mode are added heating element in doorframe, keep no fog around doorframe

Product details



1. Europe brand controller
2. Easy to disassemble the unit and facilitate maintenance
3. Adjustable shelving
4. Door locks can be equipped
5. Stainless steel structure
6. Glass door is available

Product parameters

Model	GTS-GN1200DT/D	GTS-GN1410DT/D
Product size (mm)	1340×800×2040	1480×830×2040
Refrigerant	R290	R290
Temperature (°C)	+2 ~ +8 / -18 ~ -22	+2 ~ +8 / -18 ~ -22
Net weight (Kg)	211	280
Net capacity (L)	1150	1285
Rated power (W)	TN 310; BT 720	TN 310; BT 720
Refrigeration type	Ventilated	Ventilated

Product certification



* We have the right to change the product design and configuration without informing customers in advance!

R290 +2~+8°C -18~-22°C



Plan View

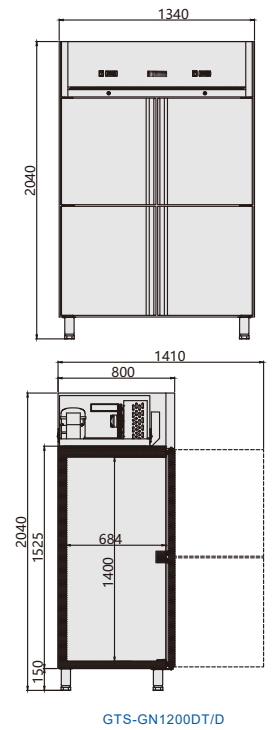

GTS-GN1200DT/D

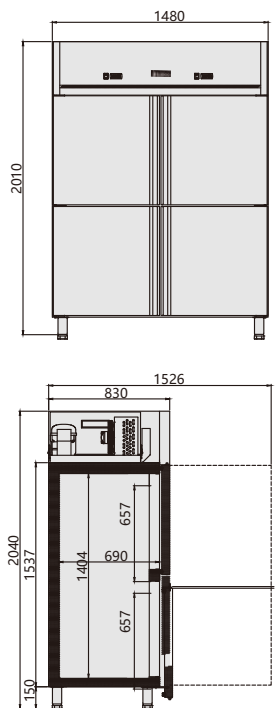

GTS-GN1410DT/D



PIZZA SANDWICH



SANDWICH COUNTER

Product features

- Stainless steel structure
- Adjustable feet and castor is available
- Ventilated cooling system
- High density insulation body
- Europe brand digital controller
- Europe brand compressor
- Smart automatic defrosting
- Interior body with round corner, easy to clean
- Self-closing door with magnetic gaskets
- The door can be interchanged by drawers

Product details



Fractional plate design, classified storage, food does not taste

Stainless steel structure

Product parameters

Model	GTS-SH2000/700	GTS-SH2000/800
Product size (mm)	1360×700×1075	1510×800×1075
Packing size (mm)	1420×740×1160	1570×840×1160
Temperature (°C)	+2~+8	+2~+8
Net weight (Kg)	101	98
Net capacity (L)	260	400
Rated power (W)	388	390
Refrigeration type	Ventilated	Ventilated

Product certification



* We have the right to change the product design and configuration without informing customers in advance!



GN Pans Configurations

GTS-SH2000/700



GTS-SH2000/800



Plan View

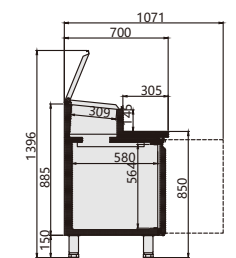
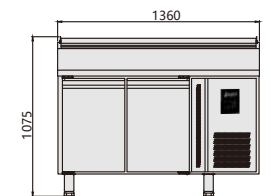

GTS-SH2000/700

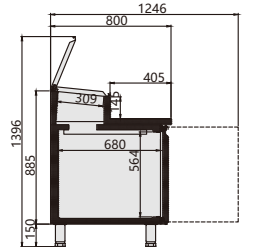
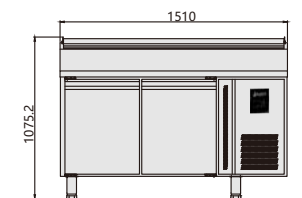

GTS-SH2000/800



GTS-SH2000/700



GTS-SH2000/800

SANDWICH COUNTER

Product features

- Stainless steel structure
- Adjustable feet and castor is available
- Ventilated cooling system
- High density insulation body
- Europe brand digital controller
- Europe brand compressor
- Smart automatic defrosting
- Interior body with round corner, easy to clean
- Self-closing door with magnetic gaskets
- The door can interchanged by drawers

Product details



Stainless steel cover can be replaced with glass cover

Product parameters

Model	GTS-SH3000/700	GTS-SH4000/700	GTS-SH3000/700-800	GTS-SH3000/800
Product size (mm)	1795×700×1075	2230×700×1075	1795×800×1075	2020×800×1075
Packing size (mm)	1840×740×1160	2260×740×1160	1840×840×1160	2080×840×1160
Temperature (°C)	+2~+8	+2~+8	+2~+8	+2~+8
Net weight (Kg)	122	139	140	154
Net capacity (L)	360	541	450	580
Rated power (W)	375	388	375	451
Refrigeration type	Ventilated	Ventilated	Ventilated	Ventilated

Product certification



* We have the right to change the product design and configuration without informing customers in advance!



GTS-SH3000/700



GTS-SH4000/700



GTS-SH3000/700-800



GTS-SH3000/800

GTS-SH3000/700
GTS-SH3000/700-800

GN Pans Configurations

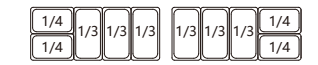

GTS-SH3000/800

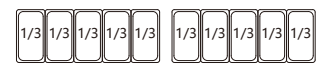

GTS-SH4000/700



Plan View

Front View

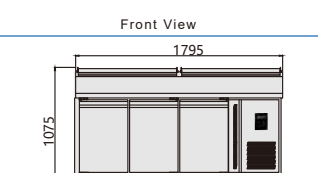

GTS-SH3000/700

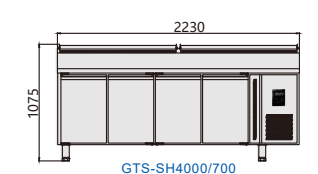

GTS-SH4000/700

Side View

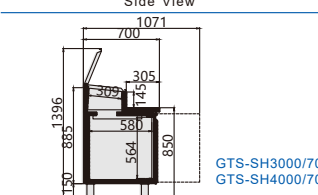

GTS-SH3000/700
GTS-SH4000/700

Plan View

Front View

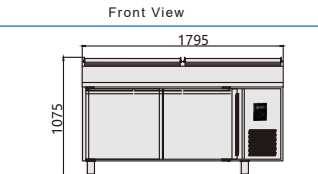

GTS-SH3000/700-800

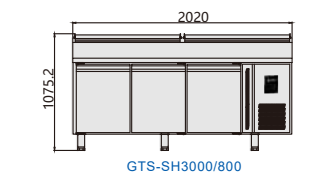

GTS-SH3000/800

Side View

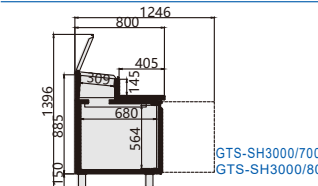

GTS-SH3000/700-800
GTS-SH3000/800

SANDWICH COUNTER

Product features

- Openable fan-shaped basin cover
- Europe standard GN 1/1 pan designed
- Stainless steel structure
- Ventilated cooling system
- High density insulation body
- Europe brand controller
- European brand compressor
- Smart automatic defrosting
- Interior body with round corner, easy to clean
- Self-closing door with magnetic gaskets
- Adjustable shelving design
- The depth of the counter can be customized to 60cm,65cm,70cm,75cm,80cm
- The door can interchanged by drawers

Product details



1. Europe brand controller
2. Adjustable shelving design
3. Gaskets can be easily to clean and changed
4. Europe standard door handle
5. Openable fan-shaped basin cover
6. Europe standard GN pan designed



GTS-GN2100TN-BS

Product parameters

Model	GTS-GN2100TN-BS	GTS-GN3100TN-BS	GTS-GN4100TN-BS
Product size (mm)	1360×700×1060	1795×700×1060	2230×700×1060
Package size (mm)	1420×740×1120	1845×740×1120	2280×740×1120
Temperature (°C)	+2~+8	+2~+8	+2~+8
Net weight (Kg)	92	113	134
Net capacity (L)	260	400	540
Rated power (W)	350	360	470
Refrigeration type	Ventilated	Ventilated	Ventilated

Product certification



*We have the right to change the product design and configuration without informing customers in advance!



GTS-GN3100TN-BS



GTS-GN4100TN-BS



GTS-GN3100TN-BS

GN Pans Configurations

GTS-GN2100TN-BS



GTS-GN3100TN-BS



GTS-GN4100TN-BS



Plan View

Front View

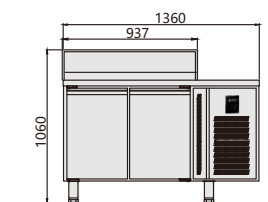

GTS-GN2100TN-BS

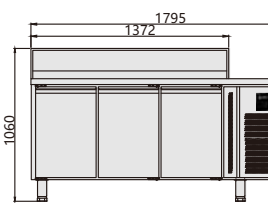

GTS-GN3100TN-BS

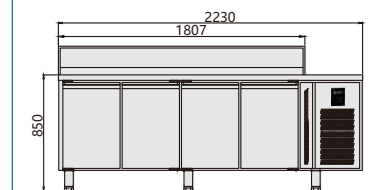

GTS-GN4100TN-BS

Side View

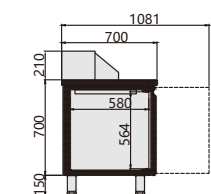

PIZZA COUNTER

Product features

- 304 Stainless Steel Structure
- 40X60 Tray & 44 x 60 Tray Adaptable Shelves
- Ventilated Cooling System
- High Density Polyurethane Insulated Structure
- Self-Closing Door with Magnetic Gasket
- Two Digital Controller
- Easy to Clean Rounded Interior Structure
- Adjustable Shelves Desing
- EU Branded Compressor
- EU Branded Digital Controller
- Automatic Defrozing System
- Doors are Adaptable for Drawer Assembling
- Adjustable Feets or Wheels are available
- R290 Gas

Product details



1. Independent two digital controller for refrigator and display.
2. Middel evaporator standart
3. Pull & Hang Stainless Steel Cover
4. According to use, placement can be made with different GN pans
5. Easy to Clean Rounded Edge Corners
6. Rounded easy to use door handles
7. For 40x60 and 45x60, Dough sheets
8. 304 Stainless steel
9. With White Marble on the work top
10. 1/6 GN, Double System, 2 Compressor, 2 Display, with wheels

Product parameters

Model	GTS-GT-SH2000/800	GTS-GT-SH3000/800	GTS-GT-SH4000/800
Product size (mm)	1620×830×1125	2200×830×1125	2785×830×1125
Temperature (°C)	+2~+8	+2~+8	+2~+8
Net weight (Kg)	125	155	185
Net capacity (L)	260	400	540
Rated power (W)	350	360	470
Refrigeration type	Ventilated	Ventilated	Ventilated

Product certification



*We have the right to change the product design and configuration without informing customers in advance!



GN Pans Configurations

GTS-GT-SH2000/800



GTS-GT-SH3000/800

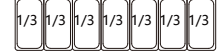

GTS-GT-SH4000/800



Plan View

Front View

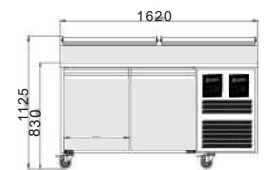

GTS-GT-SH2000/800

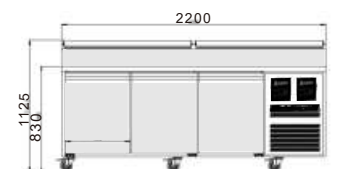

GTS-GT-SH3000/800

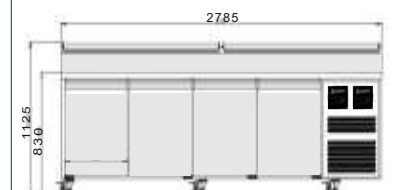

GTS-GT-SH4000/800

Side View

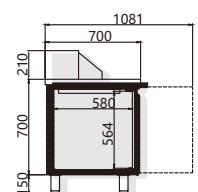

LUXURY PIZZA COUNTER

Product features

- Europe standard GN 1/1 pan & 600*400 mm for operation
- Adjustable feet and castor is available
- Stainless steel structure
- Ventilated cooling system
- High density insulation body
- Europe brand digital controller
- Europe brand compressor
- Smart automatic defrosting
- Interior body with round corner, easy to clean
- Self-closing door with magnetic gaskets
- Adjustable shelving design
- The door can interchanged by drawers

Product details

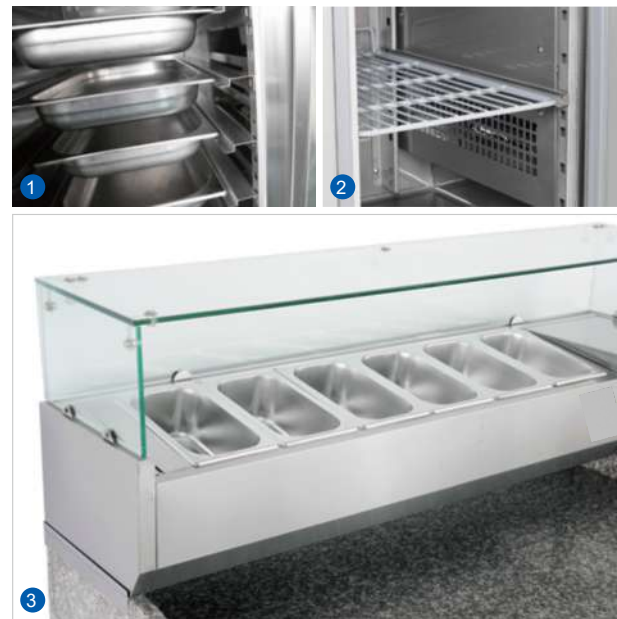

1. Europe standard GN 1/1 pan & 600*400 mm for operation
2. Adjustable shelving design
3. Cooling top display 380 series placed on the console

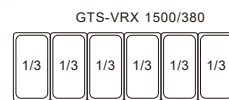

GTS-PZ1100TN/380

Product parameters

Model	GTS-PZ1100TN/380	GTS-PZ903/380	GTS-PZ1610TN/380	GTS-PZ2600TN/380
Product size (mm)	1200×800×1427	1400×700×1462	1510×800×1427	1510×800×1427
Packing size (mm)	1300×840×1060	1420×740×1200	1570×840×1060	1570×840×1060
Temperature (°C)	+2~+8	+2~+8	+2~+8	+2~+8
Net weight (Kg)	120	131	215	194
Net capacity (L)	250	390	168	390
Rated power (W)	290	321	256	320
Refrigeration type	Ventilated	Static	Ventilated	Ventilated

Product certification



* We have the right to change the product design and configuration without informing customers in advance!

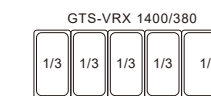

GTS-PZ903/380

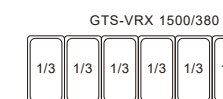

GTS-PZ1610TN/380

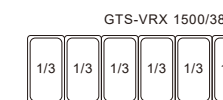

GTS-PZ2600TN/380

Marble color



Grey

Black

Beige

Plan View

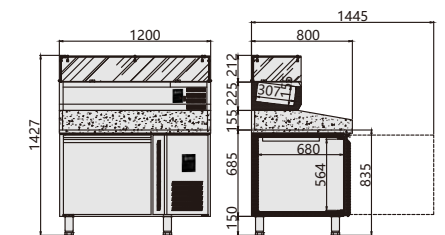

GTS-PZ1100TN/380

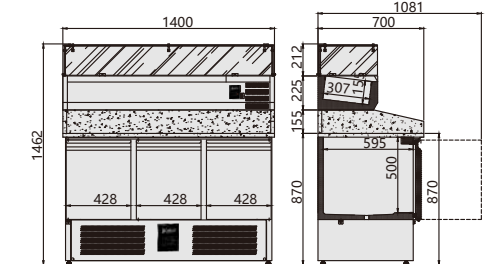

GTS-PZ903/380

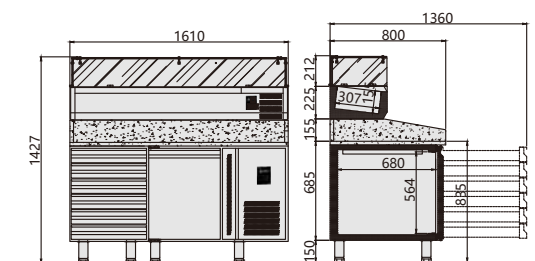

GTS-PZ1610TN/380

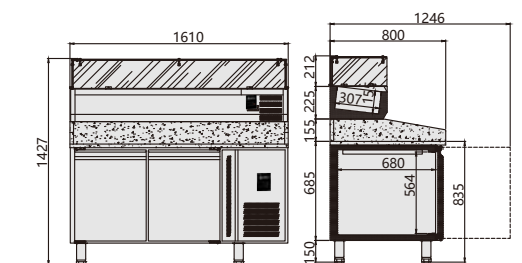

GTS-PZ2600TN/380

LUXURY PIZZA COUNTER

Product features

- Europe standard GN 1/4 pan & 600*400 mm for operation
- Adjustable feet and castor is available
- Stainless steel structure
- Ventilated cooling system
- High density insulation body
- Europe brand digital controller
- Europe brand compressor
- Smart automatic defrosting
- Interior body with round corner, easy to clean
- Self-closing door with magnetic gaskets
- Adjustable shelving design
- The door can interchanged by drawers

Product details



1. Europe branded two digital controller
2. Top digital controller
3. High quality natural marble
4. Top cooling display



Product parameters

Model	GTS-GT-PZ2600TN/330	GTS-GT-PZ3600TN/330	GTS-GT-PZ3600TN/330
Product size (mm)	1620×830×1500	2200×830×1500	2785×830×1500
Refrigerant	R290	R290	R290
Temperature (°C)	+2~+8	+2~+8	+2~+8
Net weight (Kg)	188	228	268
Net capacity (L)	260	400	580
Rated power (W)	336	360	451
Refrigeration type	Ventilated	Ventilated	Ventilated

Product certification



* We have the right to change the product design and configuration without informing customers in advance!



GTS-GT-PZ2600TN/330



GTS-GT-PZ3600TN/330



GTS-GT-PZ4600TN/330

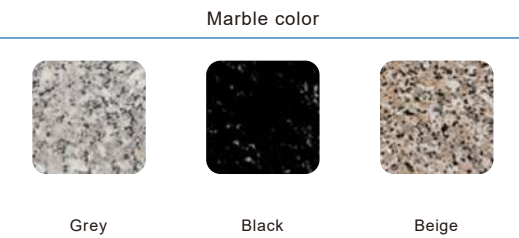

Plan View

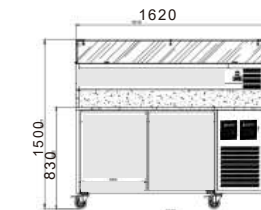

GTS-GT-PZ2600TN/330

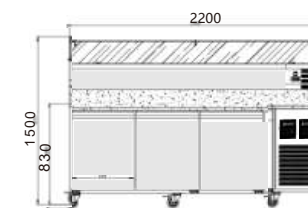

GTS-GT-PZ3600TN/330

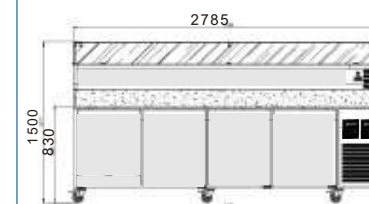

GTS-GT-PZ4600TN/330

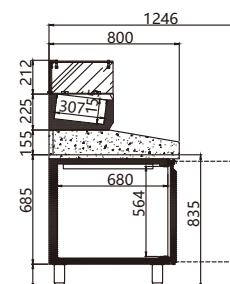

SUBWAY

Product features

- Ambience temperature: 32°C & 65% humidity
- AISI 201 stainless steel body
- Energy saving compressor, digital thermostat and high speed & low noise fan motor
- CFC free cooling gas R134a
- Fan cooling, air circulation to preserve the sustained freshness of food
- 8mm tempered glass cover
- GN pan capacity
- Nylon food preparation top
- Stainless steel hollow glass door lid, air lift support, easy opening and closing
- LED lighting for display of food freshness and color
- Stainless steel adjustable legs

Product details

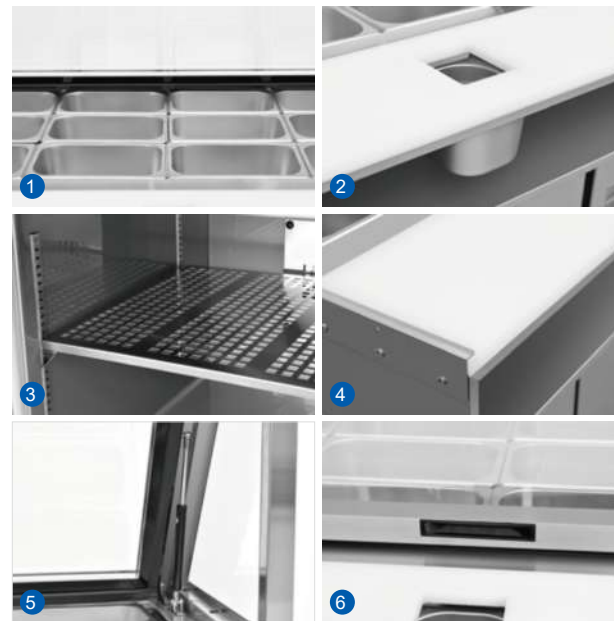

1. GN pan capacity
2. Waste bucket
3. Adjustable shelving
4. Chopping board
5. Hydraulic rod type safety glass door cover
6. Double glass cover

Product parameters

Model	GTS-QG12L1F	GTS-QG15L2F	GTS-QG18L3F
Product size (mm)	1200×900×1450	1500×900×1450	1800×900×1450
Temperature (°C)	0 ~ +10	0 ~ +10	0 ~ +10
Net capacity (L)	280	380	480
Rated power (W)	320	420	480
Product Description	(1door)	(2door)	(3door)
Refrigerant Type	R290	R290	R290
Refrigeration type	Ventilated	Ventilated	Ventilated

Product certification



* We have the right to change the product design and configuration without informing customers in advance!



GN Pans Configurations

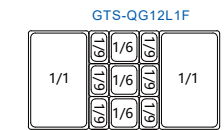



BAKERY SHOWCASE



BLAST CHILLER / FREEZER

Product features

- Ventilated cooling system
- High density insulation body
- Europe brand digital control, Dixell
- Europe brand compressor, Embraco and Tecumseh
- Smart automatic defrosting
- Interior body with round corner, easy to clean
- Self-closing door with magnetic gaskets
- Let the temperature in the cabinet drops from the normal temperature to -40°C in just 30 minutes
- It can hold the versatile GN1/1 pans and 400x600 mm bakery trays, 65mm deep.



GTSS650

Product details



1. Europe brand controller
2. Exquisite and beautiful door handles
3. Thickened high-density foam layer
4. Food probe to measure the center temperature of frozen products
5. Built in circulating fan
6. Cooling holes

Product parameters

Model	GTS-S650	GTS-BC-3T	GTS-BC-5T(-32°C)	GTS-BC-5T(-40°C)
Product size (mm)	650×620×400	710×700×560	725×795×865	800×800×1000
Package size (mm)	300×700×480	790×780×660	800×880×1100	890×890×1100
Temperature (°C)	+3 ~ -32	+3 ~ -35	+3 ~ -32	+30 ~ -40
Net weight (Kg)	29	64	70	75
Net capacity (L)	30	65	90	100
Rated power (W)	400	550	698	880
Refrigeration type	Ventilated	Ventilated	Ventilated	Ventilated

Product certification



* We have the right to change the product design and configuration without informing customers in advance!

R290 TN: +2~+8°C
R290 BT: -35~-40°C

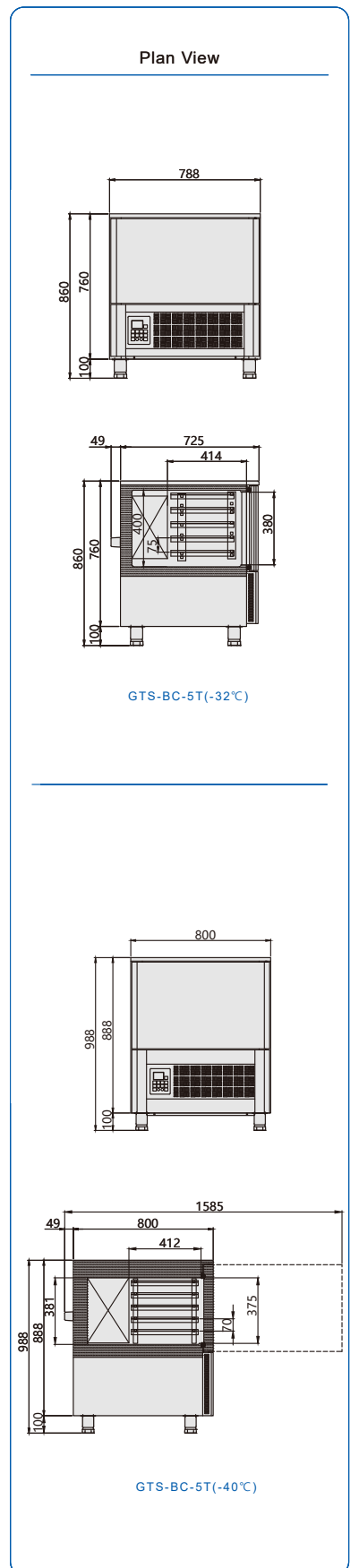

GTS-BC-5T(-32°C)
+30 ~ -32°C
5 pans



GTS-BC-5T(-40°C)
+30 ~ -40°C
5 pans

BLAST CHILLER / FREEZER

Product features

- Stainless steel structure
- Ventilated cooling system
- High density insulation body
- Europe brand digital controller , Dixell
- Europe brand compressor, Embraco and Tecumseh
- Smart automatic defrosting
- Interior body with round corner, easy to clean
- Self-closing door with magnetic gaskets
- Let the temperature in the cabinet drops from the normal temperature to -40°C in just 30 minutes
- It can hold the versatile GN1/1 pans and 400x600 mm bakery trays, 65mm deep.

Product details



It can hold the versatile GN1/1 pans and 400x600 mm bakery trays

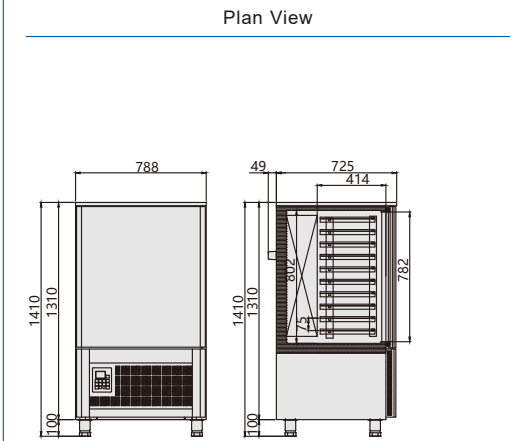
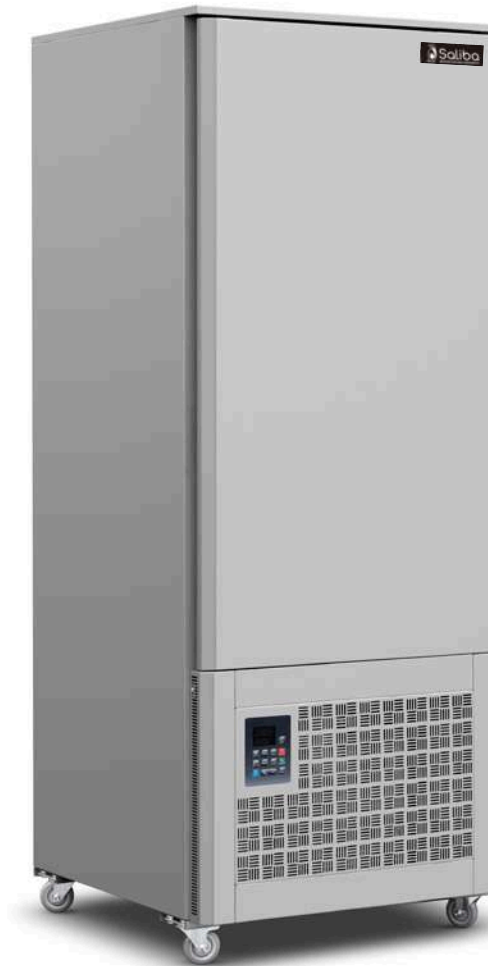

GTS-BC-10T(-2°C)

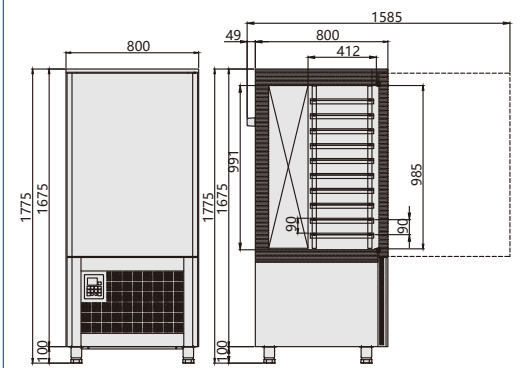

GTS-BC-10T(-40°C)

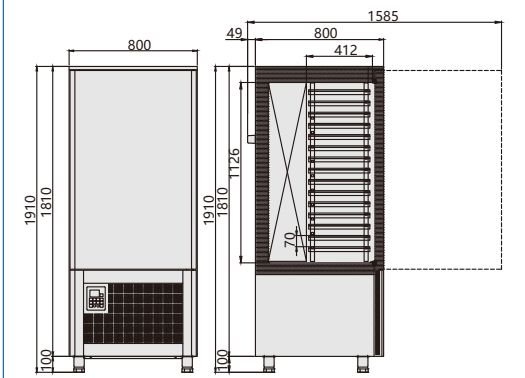

GTS-BC-15T

Product parameters

Model	GTS-BC-10T(-32°C)	GTS-BC-10T(-40°C)	GTS-BC-15T
Product size (mm)	725×795×1400	800×800×1800	800×800×1960
Package size (mm)	800×880×1560	890×890×1880	890×890×2040
Temperature (°C)	+30 ~ -32	+30 ~ -40	+30 ~ -40
Net weight (Kg)	135	150	165
Net capacity (L)	188	250	280
Rated power (W)	1050	1800	1950
Refrigeration type	Ventilated	Ventilated	Ventilated

Product certification



* We have the right to change the product design and configuration without informing customers in advance!



BLAST CHILLER / FREEZER

Product features

- Stainless steel structure
- Ventilated cooling system
- High density insulation body
- Europe brand digital controller , Dixell
- Europe brand compressor, Embraco and Tecumseh
- Smart automatic defrosting
- Interior body with round corner, easy to clean
- Self-closing door with magnetic gaskets
- Adjustable shelf, each layer can hold 2 1 / 1 parts pots
- Replaceable bullet foot or caster
- Heating wire with door frame to keep the cabinet door from cold leakage and condensation
- Upper- 25°C ~ - 30°C, lower- 35°C ~ - 40°C, double storehouse quick freezing

Product details



1. Two sets of brand temperature controllers can accurately control the temperature respectively
2. Adjustable shelf, each layer can hold 2 1 / 1 parts basins
3. Bullet feet or casters can be changed

Product parameters

Model	GTS-DF800-1(H1800)	GTS-DF800-1(H2040)
Product size (mm)	740×1100×1800	740×1100×2040
Package size (mm)	780×1160×1860	780×1160×2100
Temperature (°C)	-25~-30 / -35~-40	-25~-30 / -35~-40
Net weight (Kg)	107	107
Net capacity (L)	507 / 227	369 / 227
Rated power (W)	260 / 590	260 / 590
Refrigeration type	Ventilated	Ventilated

Product certification



* We have the right to change the product design and configuration without informing customers in advance!



GTS-DF800-1(H1800)



GTS-DF800-1(H2040)

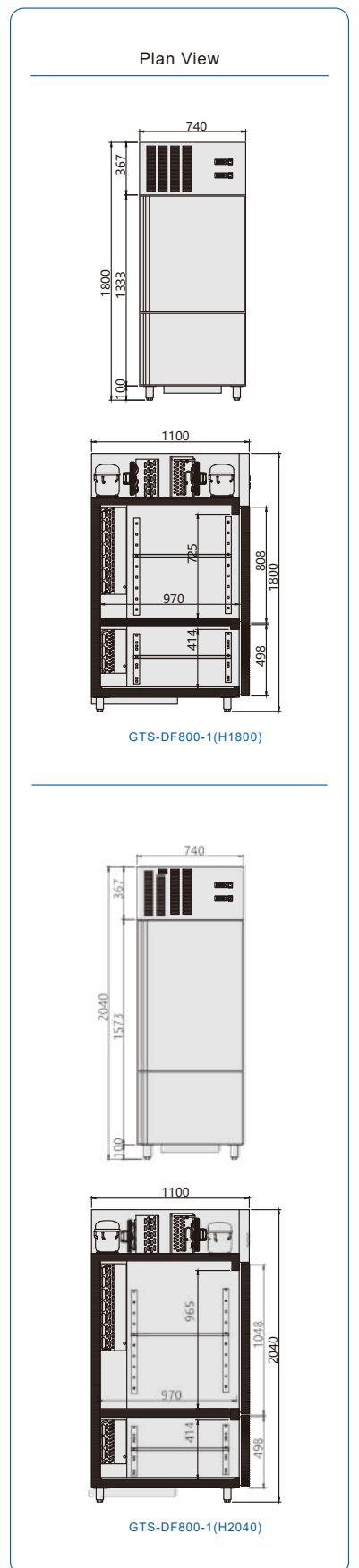

BAKERY REFRIGERATOR & FREEZER

Product features

- Europe standard 600*400mm tray designed
- Stainless steel structure
- Ventilated cooling system
- High density insulation body
- Europe brand controller
- Europe brand compressor
- Smart automatic defrosting
- Freezer models are added heating element in doorframe, keep no fog around doorframe
- Interior body with round corner, easy to clean
- Self-closing door with magnetic gaskets
- Adjustable shelving design
- The depth of the counter can be customized to 60cm,65cm,70cm,75cm,80cm

Product details



1. Europe brand controller
2. European brand compressor
3. Gaskets can be easily to clean and changed
4. Europe standard door handle
5. Porous motor heat dissipation, faster cooling
6. Adjustable feet or castor is available

Product parameters

Model	GTS-PA1100TN	GTS-PA2100TN	GTS-PA3100TN	GTS-PA1100BT	GTS-PA2100BT	GTS-PA3100BT
Product size (mm)	1200×800×850	1510×800×850	2025×800×850	1200×800×850	1510×800×850	2025×800×850
Package size (mm)	1260×840×910	1570×840×910	2080×840×910	1260×840×910	1570×840×910	2080×840×910
Temperature (°C)	+2~+8	+2~+8	+2~+8	-15~-20	-15~-20	-15~-20
Net weight (Kg)	92	113	128	96	107	138
Net capacity (L)	250	360	550	250	360	550
Rated power (W)	350	320	451	588	610	890
Refrigeration type	Ventilated	Ventilated	Ventilated	Ventilated	Ventilated	Ventilated

Product certification



* We have the right to change the product design and configuration without informing customers in advance!

R290 TN: +2~+8°C

R290 BT: -15~-20°C

Optional

Left unit

Right unit

Water basin

Plan View

Front View

Side View

Europe standard 600*400mm tray designed.

BAKERY UPRIGHT

Product features

- Europe standard 600*400mm tray designed
- Stainless steel structure
- Ventilated cooling system
- High density insulation body
- Europe brand controller
- Europe brand compressor
- Smart automatic defrosting
- Freezer models are added heating element in doorframe, keep no fog around doorframe
- Interior body with round corner, easy to clean
- Self-closing door with magnetic gaskets
- Adjustable shelving design
- The depth of the counter can be customized to 60cm,65cm,70cm,75cm,80cm

Product details

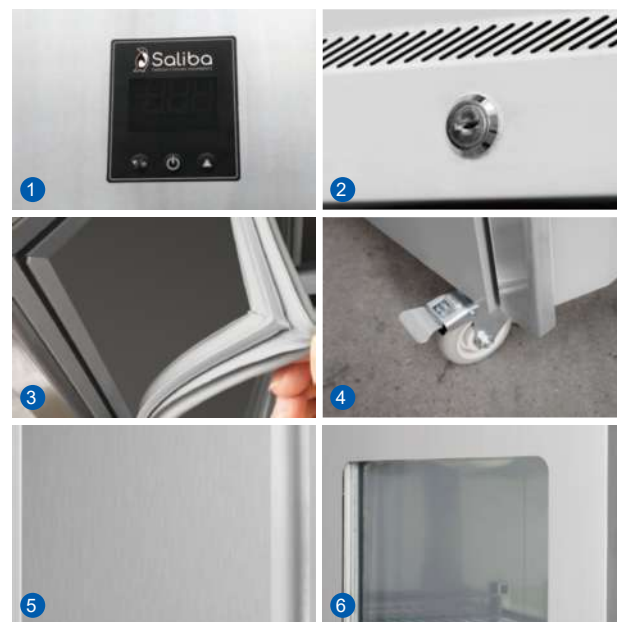

1. Europe brand controller
2. Equipped with door lock
3. Gaskets can be easily to clean and changed
4. Adjustable feet or castor is available
5. Stainless steel structure
6. Glass door is available

Product parameters

Model	GTS-PA800TN	GTS-PA800BT
Product size (mm)	740×990×2040	740×990×2040
Package size (mm)	R290	R290
Temperature (°C)	+2~+8	-18~-22
Net weight (Kg)	121	126
Net capacity (L)	610	610
Rated power (W)	328	815
Refrigeration type	Ventilated	Ventilated

Product certification



* We have the right to change the product design and configuration without informing customers in advance!

R290 TN: +2~+8°C
R290 BT: -18~-22°C



Europe standard 600*400mm tray designed.

Plan View

Front View

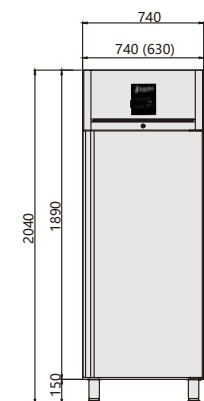

Side View

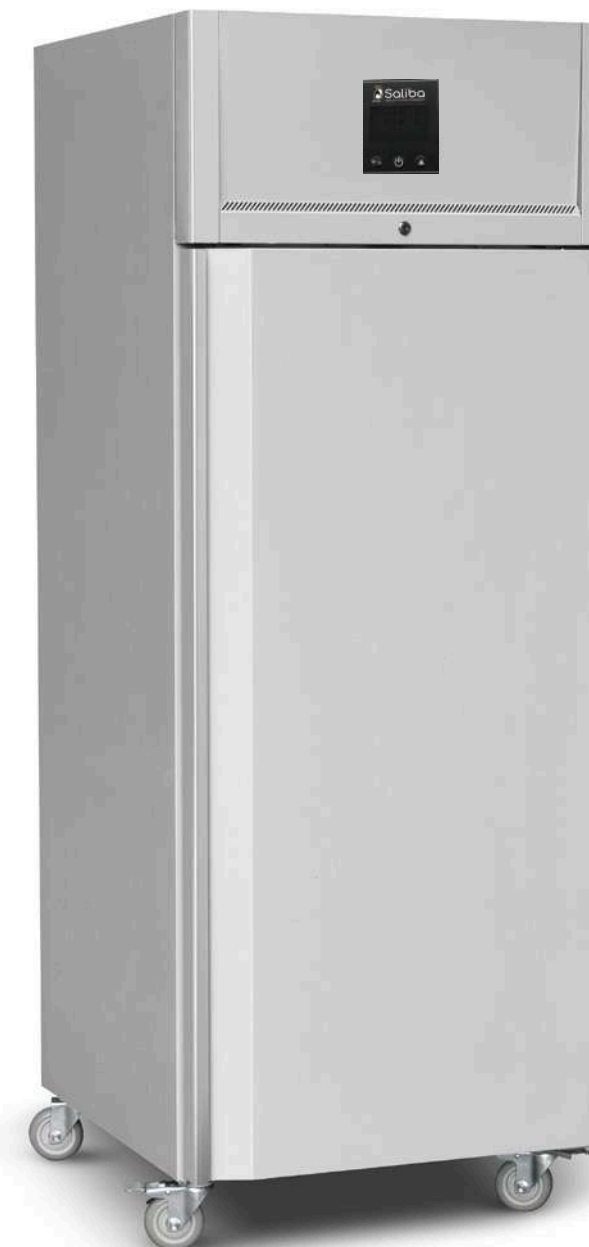
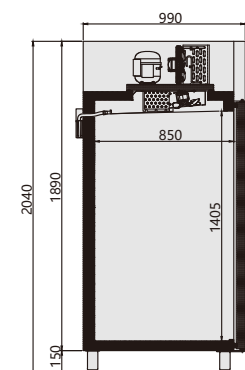



RIGHT ANGLE CAKE SHOWCASE (Stainless steel)

Product features

- Imported compressor
- All copper tube manufacturing
- Strong refrigeration, air-cooled and frost free
- Digital temperature control, microcomputer intelligent and accurate temperature control
- LED lighting, high-end atmosphere and clearer food
- High quality stainless steel base, rust free, firm and durable
- Stainless steel layer frame, strong bearing capacity, up and down adjustable stainless iron steel layer frame
- Double layer hollow glass sliding door, good cold locking effect, energy saving and power saving

Product details



1. LED lighting
2. Stainless steel layer frame can be adjusted up and down

Product parameters

Model	GTS-FCS90R2M	GTS-FCS100R2M	GTS-FCS120R2M	GTS-FCS150R2M	GTS-FCS180R2M
Product Size (mm)	900×700×1200	1000×700×1200	1200×700×1200	1500×700×1200	1800×700×1200
Temperature (°C)	+2~+8	+2~+8	+2~+8	+2~+8	+2~+8
Capacity (L)	-	-	-	-	-
Power (W)	260	277	505	586	760
Electric Current(A)	1.5	1.57	2.9	3.3	4.2
Net Weight (Kg)	185	205	215	245	290
Voltage (V)	220	220	220	220	220
Climate type	T	T	T	T	T
Refrigerant (g)	R290/95	R290/100	R290/170	R290/180	R290/240

Product certification



* We have the right to change the product design and configuration without informing customers in advance!



High quality stainless steel panel

	Silver stainless steel		White mirror stainless steel
	Black stainless steel		Black mirror stainless steel

LED lighting

	white		Warm color
--	-------	--	------------

RIGHT ANGLE CAKE SHOWCASE (Stainless steel)

Product features

- Imported compressor
- All copper tube manufacturing
- Strong refrigeration, air-cooled and frost free
- Digital temperature control, microcomputer intelligent and accurate temperature control
- LED lighting, high-end atmosphere and clearer food
- High quality stainless steel base, rust free, firm and durable
- Stainless steel layer frame, strong bearing capacity, up and down adjustable stainless iron steel layer frame
- Double layer hollow glass sliding door, good cold locking effect, energy saving and power saving

Product details



1. LED lighting
2. Stainless steel layer frame can be adjusted up and down
3. Right angle double-layer hollow tempered glass

Product parameters

Model	GTS-FCS90R3M	GTS-FCS100R3M	GTS-FCS120R3M	GTS-FCS150R3M	GTS-FCS180R3M
Product Size (mm)	900×700×1300	1000×700×1300	1200×700×1300	1500×700×1300	1800×700×1300
Temperature (°C)	+2~+8	+2~+8	+2~+8	+2~+8	+2~+8
Capacity (L)	-	-	-	-	-
Power (W)	222	295	525	760	805
Electric Current(A)	1.33	1.64	2.99	4.3	4.24
Net Weight (Kg)	190	215	230	265	320
Voltage (V)	220	220	220	220	220
Climate type	T	T	T	T	T
Refrigerant (g)	R290/95	R290/110	R290/190	R290/210	R290/240

Product certification



* We have the right to change the product design and configuration without informing customers in advance!



Plan View

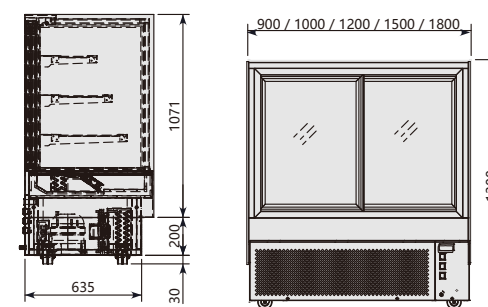

High quality stainless steel panel

- Silver stainless steel
- Black stainless steel
- White mirror stainless steel
- Black mirror stainless steel

LED lighting

- white
- Warm color

DOUBLE ARC CAKE SHOWCASE (Stainless steel)

Product features

- Imported compressor
- All copper tube manufacturing
- Strong refrigeration, air-cooled and frost free
- Digital temperature control, microcomputer intelligent and accurate temperature control
- LED lighting, high-end atmosphere and clearer food
- High quality stainless steel base, rust free, firm and durable
- Stainless steel layer frame, strong bearing capacity, up and down adjustable stainless iron steel layer frame
- Double layer hollow glass sliding door, good cold locking effect, energy saving and power saving

Product details



1. LED lighting
2. Europe brand controller
3. Double arc double-layer hollow tempered glass

Product parameters

Model	GTS-FCS90C2M	GTS-FCS100C2M	GTS-FCS120C2M	GTS-FCS150C2M	GTS-FCS180C2M
Product Size (mm)	900×680×1200	1000×680×1200	1200×680×1200	1500×680×1200	1800×680×1200
Temperature (°C)	+2~+8	+2~+8	+2~+8	+2~+8	+2~+8
Capacity (L)	-	-	-	-	-
Power (W)	-	260	500	-	-
Electric Current(A)	-	1.48	2.8	-	-
Net Weight (Kg)	-	190	205	-	-
Voltage (V)	220	220	220	220	220
Climate type	T	T	T	T	T
Refrigerant (g)	R290/-	R290/100	R290/180	R290/-	R290/-

Product certification



* We have the right to change the product design and configuration without informing customers in advance!



High quality stainless steel panel

- Silver stainless steel
- White mirror stainless steel
- Black stainless steel
- Black mirror stainless steel

LED lighting

- white
- Warm color

DOUBLE ARC CAKE SHOWCASE (Stainless steel)

Product features

- Imported compressor
- All copper tube manufacturing
- Strong refrigeration, air-cooled and frost free
- Digital temperature control, microcomputer intelligent and accurate temperature control
- LED lighting, high-end atmosphere and clearer food
- High quality stainless steel base, rust free, firm and durable
- Stainless steel layer frame, strong bearing capacity, up and down adjustable stainless iron steel layer frame
- Double layer hollow glass sliding door, good cold locking effect, energy saving and power saving

Product details

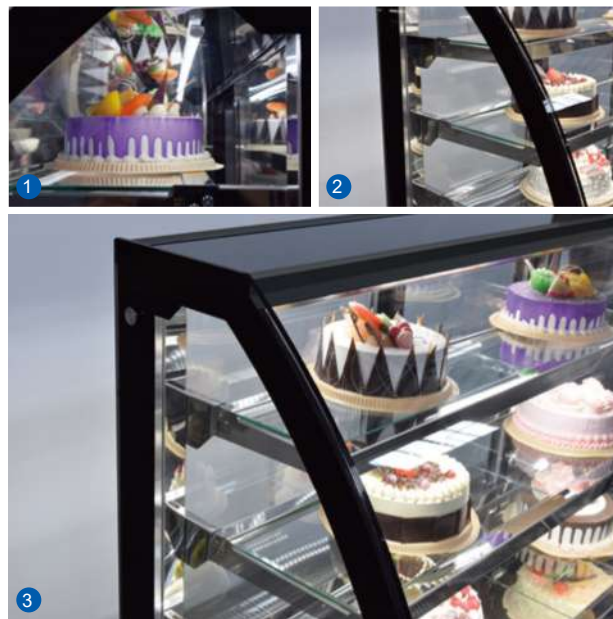

1. LED lighting
2. Stainless steel layer frame can be adjusted up and down
3. Double arc double-layer hollow tempered glass

Product parameters

Model	GTS-FCS90C3M	GTS-FCS100C3M	GTS-FCS120C3M	GTS-FCS150C3M	GTS-FCS180C3M
Product Size (mm)	900×680×1300	1000×680×1300	1200×680×1300	1500×680×1300	1800×680×1300
Temperature (°C)	+2~+8	+2~+8	+2~+8	+2~+8	+2~+8
Capacity (L)	-	-	-	-	-
Power (W)	-	283	517	752	-
Electric Current(A)	-	1.8	2.9	4.3	-
Net Weight (Kg)	-	200	215	250	-
Voltage (V)	220	220	220	220	220
Climate type	T	T	T	T	T
Refrigerant (g)	R290/-	R290/110	R290/190	R290/180	-

Product certification



* We have the right to change the product design and configuration without informing customers in advance!



Plan View

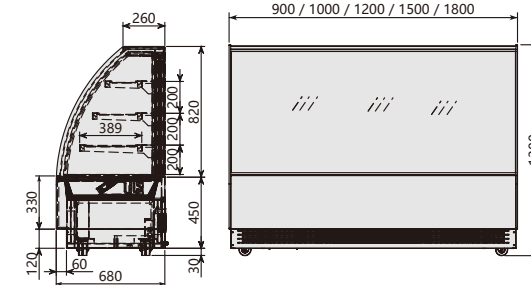

High quality stainless steel panel

- Silver stainless steel
- Black stainless steel
- White mirror stainless steel
- Black mirror stainless steel

LED lighting

- white
- Warm color

RIGHT ANGLE CAKE SHOWCASE (Stainless steel upgrade)

Product features

- Imported compressor
- All copper tube manufacturing
- Strong refrigeration, air-cooled and frostfree
- Digital temperature control, microcomputer intelligent and accurate temperature control
- LED lighting, high-end atmosphere and clearer food
- High quality stainless steel base, rust free, firm and durable
- Stainless steel layer frame, strong bearing capacity, up and down adjustable stainless iron steel layer frame
- Double layer hollow glass sliding door, good cold locking effect, energy saving and power saving

Product details



1. LED lighting
2. Stainless steel layer frame can be adjusted up and down
3. Right angle double tempered glass

Product parameters

Model	GTS-SC700FR2	GTS-SC1000FR2	GTS-SC1200FR2	GTS-SC1500FR2
Product Size (mm)	700×650×1200	1000×650×1200	1200×650×1200	1500×650×1200
Temperature (°C)	+2 ~ +8	+2 ~ +8	+2 ~ +8	+2 ~ +8
Capacity (L)	-	-	400	-
Power (W)	-	-	-	-
Electric Current(A)	-	-	-	-
Net Weight (Kg)	-	-	-	-
Voltage (V)	220V/50~60HZ	220V/50~60HZ	220V/50~60HZ	220V/50~60HZ
Climate type	-	-	-	-
Refrigerant	R290	R290	R290	R290

Product certification



* We have the right to change the product design and configuration without informing customers in advance!



High quality stainless steel panel

- Silver stainless steel
- White mirror stainless steel
- Black stainless steel
- Black mirror stainless steel

LED lighting

- white
- Warm color

DOUBLE ARC CAKE SHOWCASE (Stainless steel upgrade)

Product features

- Imported compressor
- All copper tube manufacturing
- Strong refrigeration, air-cooled and frost free
- Digital temperature control, microcomputer intelligent and accurate temperature control
- LED lighting, high-end atmosphere and clearer food
- High quality stainless steel base, rust free, firm and durable
- Stainless steel layer frame, strong bearing capacity, up and down adjustable stainless iron steel layer frame
- Double layer hollow glass sliding door, good cold locking effect, energy saving and power saving

Product details



1. Digital temperature control
2. Brushed stainless steel panel
3. Arc double-layer tempered glass

Product parameters

Model	GTS-SC700CR2	GTS-SC1000CR2	GTS-SC1200CR2	GTS-SC1500CR2
Product Size (mm)	700×650×1200	1000×650×1200	1200×650×1200	1500×650×1200
Temperature (°C)	+2 ~ +8	+2 ~ +8	+2 ~ +8	+2 ~ +8
Capacity (L)	-	-	-	-
Power (W)	-	-	-	-
Electric Current(A)	-	-	-	-
Net Weight (Kg)	-	-	-	-
Voltage (V)	220V/50~60HZ	220V/50~60HZ	220V/50~60HZ	220V/50~60HZ
Climate type	-	-	-	-
Refrigerant (g)	R290	R290	R290	R290

Product certification



* We have the right to change the product design and configuration without informing customers in advance!



High quality stainless steel panel

	Silver stainless steel		White mirror stainless steel
	Black stainless steel		Black mirror stainless steel

LED lighting

	white		Warm color
--	-------	--	------------

RIGHT ANGLE CAKE SHOWCASE SERIES (Marble style)

Product features

- Imported compressor
- All copper tube manufacturing
- Strong refrigeration, air cooling and frost free
- Multifunctional digital temperature control, more convenient operation
- LED lighting, high-end atmosphere and clearer food
- High quality marble base, a variety of marble colors
- Stable aluminum alloy layer frame, super load-bearing
- Double layer hollow glass sliding door, good cold locking effect, energy saving and power saving

Product details



1. Multifunctional digital temperature control, more convenient operation
2. Stable aluminum alloy layer frame, super load-bearing
3. High quality marble base, a variety of marble colors
4. Thickened tempered glass



Product parameters

Model	GTS-WZ1-4R	GTS-WZ1-5R	GTS-WZ1-6R	GTS-WZ1-7R	GTS-WZ1-8R
Product Size (mm)	1200×800×1300	1500×800×1300	1800×800×1300	2000×800×1300	2400×800×1300
Temperature (°C)	+2~+8	+2~+8	+2~+8	+2~+8	+2~+8
Capacity (L)	-	-	738	-	-
Power (W)	800	900	1000	1200	1350
Electric Current(A)	-	-	-	-	-
Net Weight (Kg)	-	-	420	-	-
Voltage (V)	220V/50HZ	220V/50HZ	220V/50HZ	220V/50HZ	220V/50HZ
Climate type	N	N	N	N	N
Refrigerant	R290	R290	R290	R290	R290

Product certification



*We have the right to change the product design and configuration without informing customers in advance!

Multicolor marble bases election

black

White stripe

Pure white

LED lighting

white

Warm color

RIGHT ANGLE TABLE SHOWCASE

Product features

- Imported compressor
- All copper tube manufacturing
- Strong refrigeration, air cooling and frost free
- Intelligent temperature control, microcomputer intelligent precise temperature control
- Classic energy-saving LED lamp, high-end atmosphere, clearer food
- High quality black plexiglass and stainless steel panel, beautiful and durable
- Adjustable layer frame up and down, with strong bearing capacity
- Double layer hollow tempered glass, good cold locking effect, energy saving and power saving

Product details



1. Europe brand controller
2. High quality stainless steel panel
3. Right angle ultra white tempered glass
4. Double layer hollow glass movable door
5. Beveled stainless steel layer frame
6. Heat dissipation holes

Product parameters

Model	GTS-TT700F	GTS-TT900F	GTS-TT1200F	GTSTT1500F
Product Size (mm)	700×560×730	900×560×730	1200×560×730	1500×560×730
Temperature (°C)	+2~+8°C	+2~+8°C	+2~+8°C	+2~+8°C
Capacity (L)	-	160	-	-
Power (W)	-	80	-	-
Electric Current(A)	1.3	1.4	1.7	2.1
Net Weight (Kg)	70	80	100	120
Voltage (V)	230	230	230	230
Climate type	5/7	5/7	5/7	5/7
Refrigerant (g)	R290/ 82	R290/ 88	R290/ 100	R290/ 175

Product certification



* We have the right to change the product design and configuration without informing customers in advance!





High quality stainless steel panel

- Silver stainless steel
- Black stainless steel
- White mirror stainless steel
- Black mirror stainless steel

LED lighting

- white
- Warm color

ARC TABLE SHOWCASE

Product features

- Imported compressor
- All copper tube manufacturing
- Strong refrigeration, air cooling and frost free
- Intelligent temperature control, microcomputer intelligent precise temperature control
- Classic energy-saving LED lamp, high-end atmosphere, clearer food
- High quality black plexiglass and stainless steel panel, beautiful and durable
- Adjustable layer frame up and down, with strong bearing capacity
- Double layer hollow tempered glass, good cold locking effect, energy saving and power saving

Product details



1. Europe brand controller
2. LED lighting
3. Arc ultra white tempered glass
4. Double layer hollow glass movable door
5. Beveled stainless steel layer frame
6. Heat dissipation holes

Product parameters

Model	GTS-TT700C	GTS-TT900C	GTS-TT1200C	GTS-TT1500C
Product Size (mm)	700×560×730	900×560×730	1200×560×730	1500×560×730
Temperature (°C)	+2~+8°C	+2~+8°C	+2~+8°C	+2~+8°C
Capacity (L)	-	-	-	-
Power (W)	-	-	-	-
Electric Current(A)	1.3	1.4	1.7	2.1
Net Weight (Kg)	67	77	97	115
Voltage (V)	230	230	230	230
Climate type	5/7	5/7	5/7	5/7
Refrigerant (g)	R290/ 82	R290/ 88	R290/ 100	R290/ 175

Product certification



* We have the right to change the product design and configuration without informing customers in advance!





High quality stainless steel panel

- Silver stainless steel
- Black stainless steel
- White mirror stainless steel
- Black mirror stainless steel

LED lighting

- white
- Warm color



BAKERY SHOWCASE

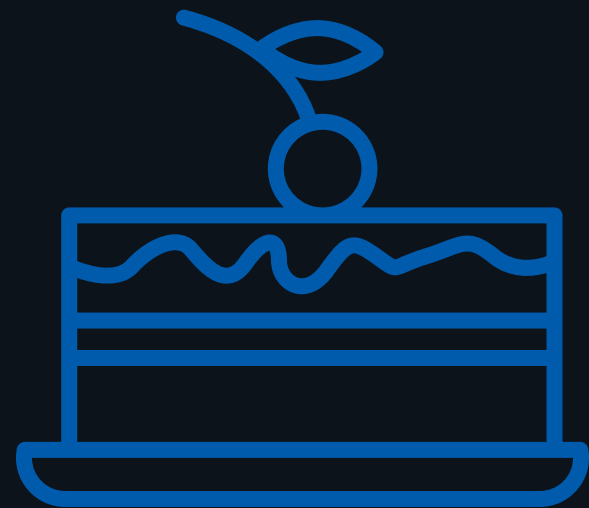

VERTICAL CAKE SHOWCASE (Gold aluminum alloy)

Product features

- Imported compressor
- All copper tube manufacturing
- Strong refrigeration, air cooling and frost free
- Digital temperature control, microcomputer intelligent and accurate temperature control
- Heating wire, degree film, hot gas demisting
- Automatic humidification keeps the moisture in the box at all times, making the food taste better
- Multi layer led warm lighting makes the food in the cabinet clear at a glance
- 360 degree rotation thickened glass shelf for omni-directional display
- Increase the heat dissipation hole, timely heat dissipation and prolong the service life of the machine
- Universal caster

Product details



1. Europe brand controller
2. U-shaped aluminum alloy door handle
3. Tempered glass turntable that can rotate 360 degrees
4. Exquisite door locks
5. Arc corner design
6. Double layer hollow ultra white tempered glass

Product parameters

Model	GTS-FG418L1-GA	GTS-FG600L2-GA	GTS-FG828L2-GA	GTS-FG1250L3-GA
Product Size (mm)	650×650×1860	925×800×1860	1245×650×1860	1840×650×1860
Temperature (°C)	+2~+8	+2~+8	+2~+8	+2~+8
Capacity (L)	418	600	828	1250
Power (W)	480	540	765	816
Electric Current(A)	2.8	3.2	3.5	4.46
Net Weight (Kg)	145	140	180	390
Voltage (V)	220	220	220	220
Climate type	T	T	T	T
Refrigerant (g)	R290/120	R290/-	R290/-	R290/240

Product certification



*We have the right to change the product design and configuration without informing customers in advance!

GTS-FG418L1-GA Single door vertical cake showcase

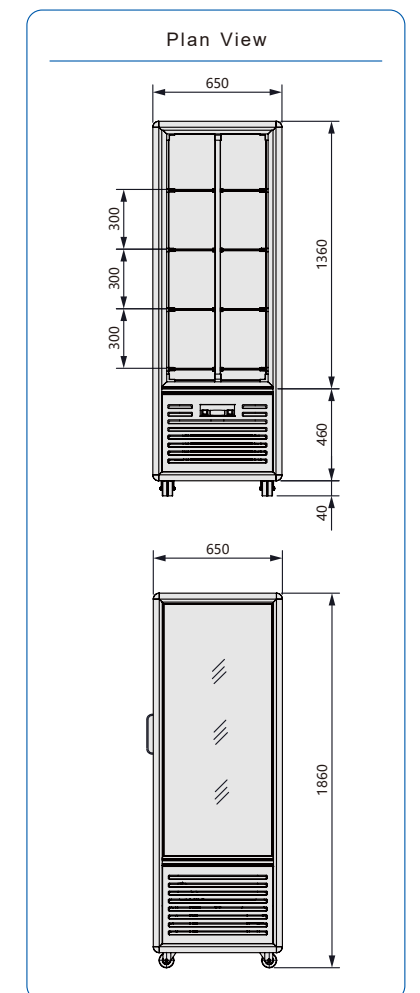
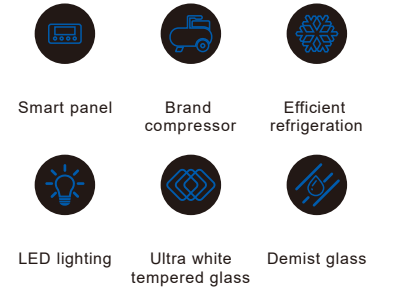

Multiple color choices:



Golden

Silvery

GTS-FG828L2-GA

Double door vertical cake show case



Smart panel	Brand compressor	Efficient refrigeration
LED lighting	Ultra white tempered glass	Demist glass

Plan View

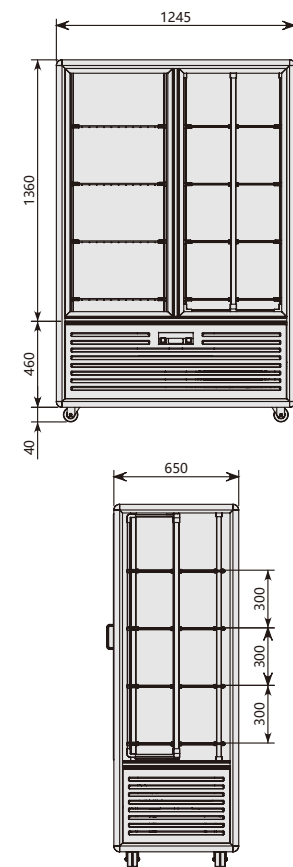

Multiple color choices:

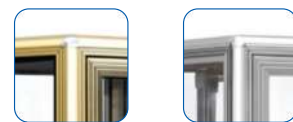

Golden

Silvery



GTS-FG1250L3-GA

Three door vertical cake show case



Smart panel	Brand compressor	Efficient refrigeration
LED lighting	Ultra white tempered glass	Demist glass

Plan View

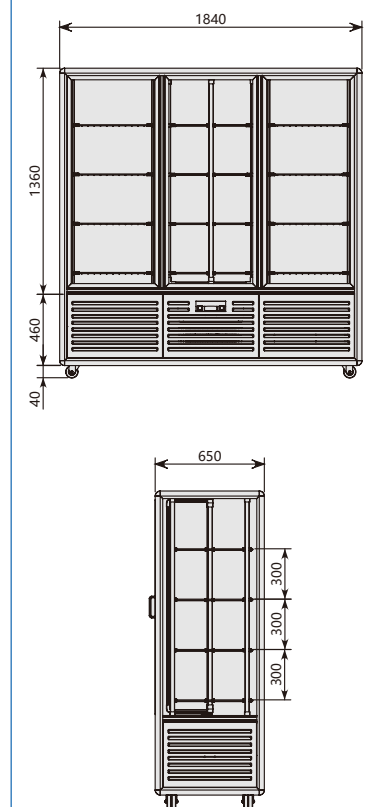

Multiple color choices:



Golden

Silvery



FG600L2-GA
Hexa hedron vertical cake show case



Smart panel	Brand compressor	Efficient refrigeration
LED lighting	Ultra white tempered glass	Demist glass

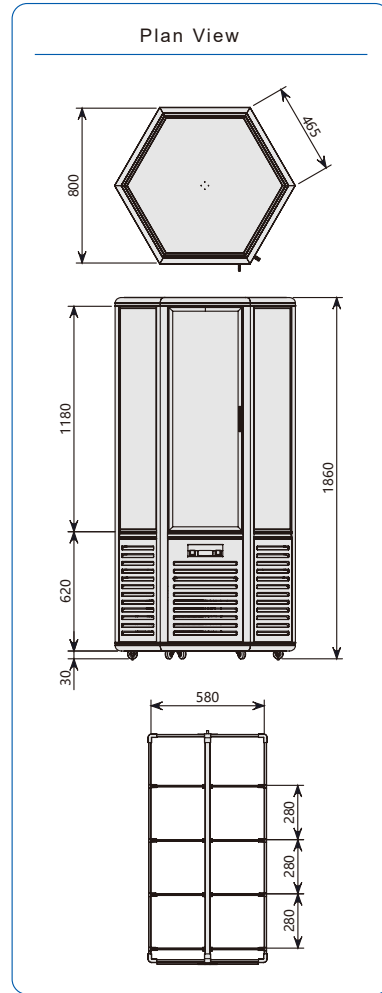

Multiple color choices:

Golden	Silvery



VERTICAL CAKE SHOWCASE (Silver aluminum alloy)

Product features

- Imported compressor
- All copper tube manufacturing
- Strong refrigeration, air cooling and frost free
- Digital temperature control, microcomputer intelligent and accurate temperature control
- Heating wire, degree film, hot gas demisting
- Automatic humidification keeps the moisture in the box at all times, making the food taste better
- Multi layer led warm lighting makes the food in the cabinet clear at a glance
- 360 degree rotation thickened glass shelf for omni-directional display
- Increase the heat dissipation hole, timely heat dissipation and prolong the service life of the machine
- Universal caster

Product details



1. Europe brand controller
2. U-shaped aluminum alloy door handle
3. Tempered glass turntable that can rotate 360 degrees
4. Exquisite door locks
5. Arc corner design
6. LED lighting

Product parameters

Model	GTS-FG418L1-A	GTS-FG600L2-A	GTS-FG828L2-A	GTS-FG1250L3-A
Product Size (mm)	650×650×1860	925×800×1860	1245×650×1860	1840×650×1860
Temperature (°C)	+2~+8	+2~+8	+2~+8	+2~+8
Capacity (L)	418	600	828	1250
Power (W)	480	540	765	816
Electric Current(A)	2.8	3.2	3.5	4.46
Net Weight (Kg)	145	140	180	390
Voltage (V)	220	220	220	220
Climate type	T	T	T	T
Refrigerant (g)	R290/120	R290/-	R290/-	R290/240

Product certification



* We have the right to change the product design and configuration without informing customers in advance!

GTS-FG418L1-A Single door vertical cake showcase

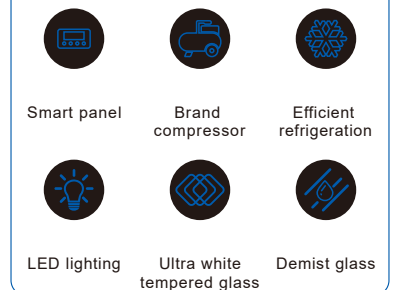

Plan View

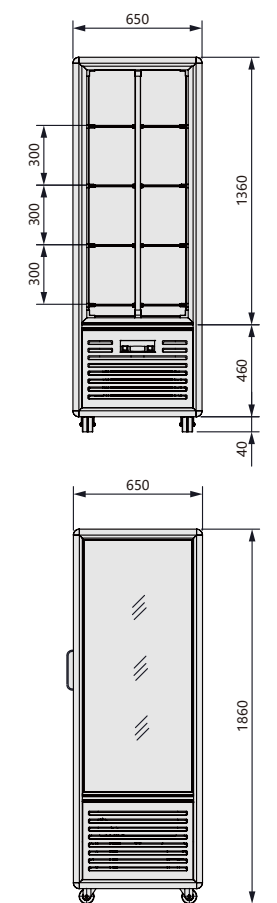

Multiple color choices:



Golden

Silvery

GTS-FG828L2-A Double door vertical cake showcase



Smart panel	Brand compressor	Efficient refrigeration
LED lighting	Ultra white tempered glass	Demist glass

Plan View

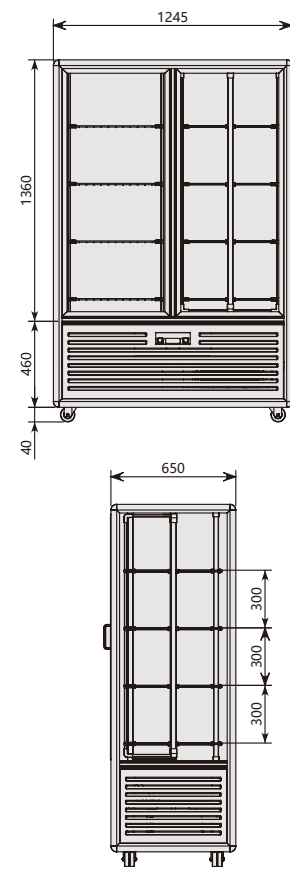

Multiple color choices:



Golden

Silvery

GTS-FG1250L3-A Three door vertical cake showcase



Smart panel	Brand compressor	Efficient refrigeration
LED lighting	Ultra white tempered glass	Demist glass

Plan View

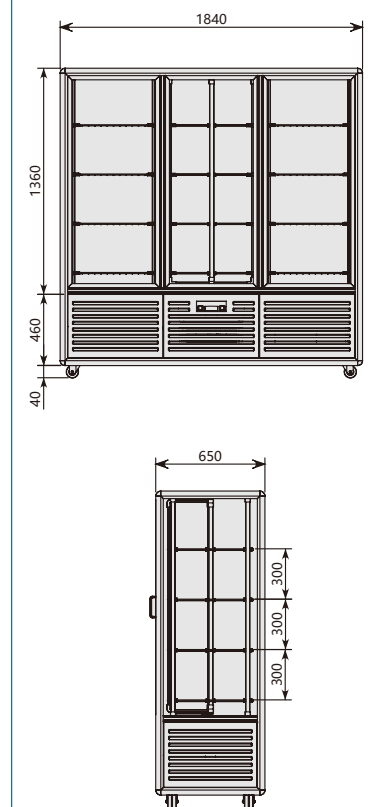

Multiple color choices:



Golden

Silvery

GTS-FG600L2-A
Hexa hedron verticalcakeshowcase



Smart panel	Brand compressor	Efficient refrigeration
LED lighting	Ultra white tempered glass	Demist glass

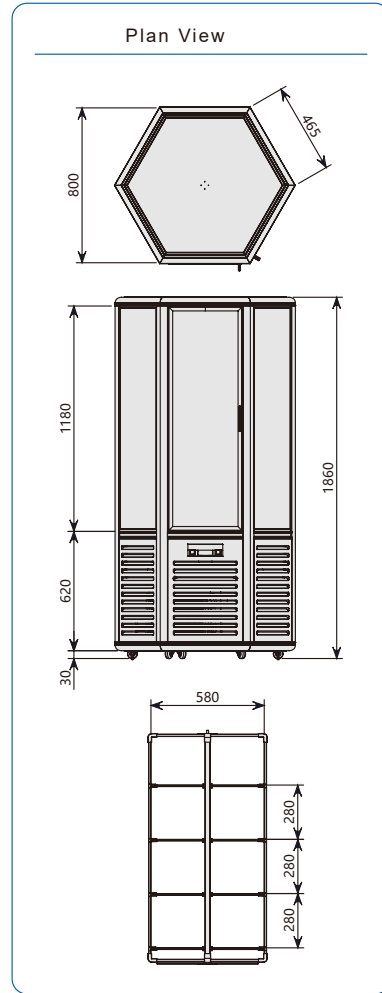

Multiple color choices:

Golden	Silvery



SINGLE DOOR VERTICAL CAKE SHOWCASE (Stainless steel)

Product features

- Imported compressor
- All copper tube manufacturing
- Strong refrigeration, air cooling and frost free
- Digital temperature control, microcomputer intelligent and accurate temperature control
- Heating wire, degree film, hot gas demisting
- Automatic humidification keeps the moisture in the box at all times, making the food taste better
- Multi layer led warm lighting makes the food in the cabinet clear at a glance
- 360 degree rotation thickened glass shelf for omni-directional display
- Increase the heat dissipation hole, timely heat dissipation and prolong the service life of the machine
- Universal caster

Product details



1. Europe brand controller
2. U-shaped aluminum alloy door handle
3. Tempered glass turntable that can rotate 360 degrees
4. Exquisite door locks
5. Cooling holes on all sides of the base
6. Multiple door seals

Product parameters

Model	GTS-FG418L1-S	GTS-FG418L1-SB	GTS-FG418L1-GM	GTS-FG418L1-BS
Product Size (mm)	650×650×1860	650×650×1860	650×650×1860	650×650×1860
Temperature (°C)	+2~+8	+2~+8	+2~+8	+2~+8
Capacity (L)	418	418	418	418
Power (W)	480	480	480	480
Electric Current(A)	2.8	2.8	2.8	2.8
Net Weight (Kg)	145	145	145	145
Voltage (V)	220	220	220	220
Climate type	T	T	T	T
Refrigerant (g)	R290/120	R290/120	R290/120	R290/120

Product certification



* We have the right to change the product design and configuration without informing customers in advance!



International Standard Color Card for Panel Paint and Coatings



GTS-FG418L1-S



GTS-FG418L1-SB



GTS-FG418L1-GM



GTS-FG418L1-BS



ICE CREAM SHOWCASE



TABLE TOP ICE CREAM SHOWCASE

Product features

- Internal configuration GN1/3 pan designed
- Stainless steel structure
- Static cooling system
- High density insulation body
- Europe brand controller
- European brand compressor
- Can be inserted into the bar, glass door can be customized front or back opening
- The door body is fixed with button moment hinge, and the location of the door can be selected at will
- The cabinet is equipped with LED lights around the top to make the cabinet fresh and bright
- The cabinet is equipped with a large area of heat dissipation hole, effective heat dissipation, the unit can be used for a longer time

Product details



1. Europe brand controller.
2. Surrounded by LED lighting.
3. Button hinge, freely parked without falling off.
4. Three GN1/3 pan.
5. Ultra white tempered glass.
6. Sealing strip.

Product parameters

Model	GTS-M3
Product Size (mm)	650×740×370
Temperature (°C)	-16 ~ -18
Refrigerant (g)	R290/ 110
Power (W)	500
Electric Current(A)	2.3
Net Weight (Kg)	65
Voltage (V)	220V/50Hz
Climate type	N
Gastronorm Containers	1/3

Product certification



* We have the right to change the product design and configuration without informing customers in advance!



LED



GN Pans Configurations

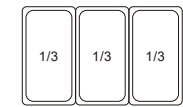

Plan View

Top View

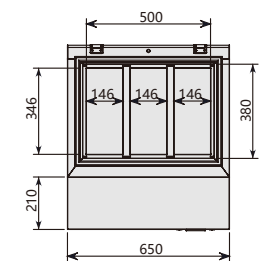

Front View

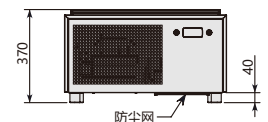

Side View

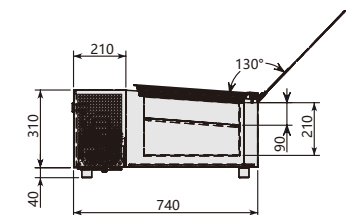

ICE CREAM SHOWCASE (Ice Cream Display Cabinet)

Product features

- Europe brand controller
- European brand compressor
- All copper tube manufacturing
- Strong refrigeration, air cooling and frost free
- Heating wire, degree film, hot gas demisting
- High quality marble base
- Universal caster
- LED lighting
- Impact resistant double layer explosion-proof glass
- Internal configuration GN1/3 pan designed

Product details



1. Europe brand controller.
2. Hidden LED lamp tube.
3. Internal temperature display.
4. 10 GN1/3 pan.
5. Glass movable door with handle.
6. Thickened explosion-proof glass.

Product parameters

Model	GTS-ICDC-1000
Product Size (mm)	1030×900×1250
Temperature (°C)	-16 ~ -20
Refrigerant (g)	R290
Power (W)	380
Electric Current(A)	1100
Net Weight (Kg)	6.5
Voltage (V)	230 V
Climate type	-
Gastronorm Containers	1/3×10

Product certification



*We have the right to change the product design and configuration without informing customers in advance!



GN Pans Configurations

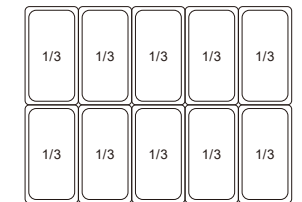

Plan View

Top View

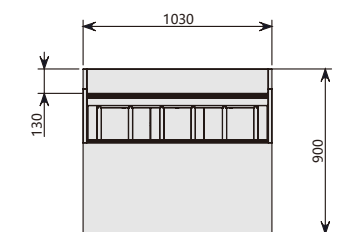

Front View

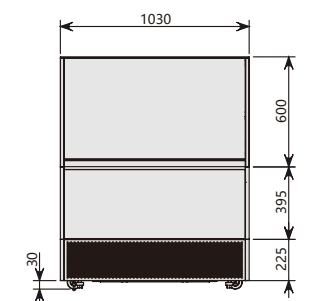

Side View

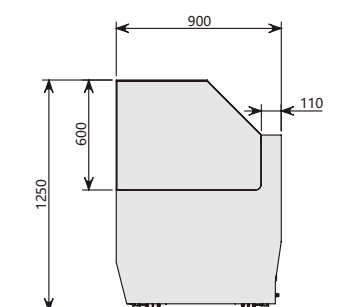

FRONT DOOR ICE CREAM SHOWCASE

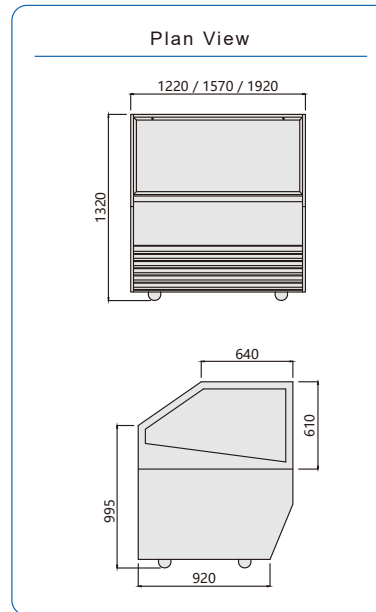
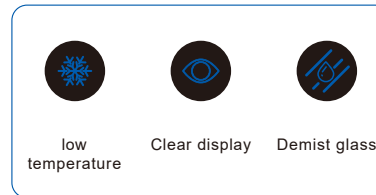

Product features

- Imported compressor
- All copper tube manufacturing
- Strong refrigeration, air cooling and frost free
- Digital temperature control, microcomputer intelligent and accurate temperature control
- Heating wire, degree film, hot gas demisting
- Natural marble base
- Universal caster

Product parameters

Model	GTS-ISA-1200	GTS-ISA-1500	GTS-ISA-1800
Product Size (mm)	1220×1080×1320	1570×1080×1320	1920×1080×1320
Temperature (°C)	-16 ~ -20	-16 ~ -20	-16 ~ -20
Capacity (L)	380	480	600
Power (W)	1300	1450	1800
Electric Current(A)	6.5	7.6	9.0
Gastronorm Containers	1/3×12	1/3×16	1/3×20

Product certification



* We have the right to change the product design and configuration without informing customers in advance!

45° CORNER GLASS ICE CREAM SHOWCASE

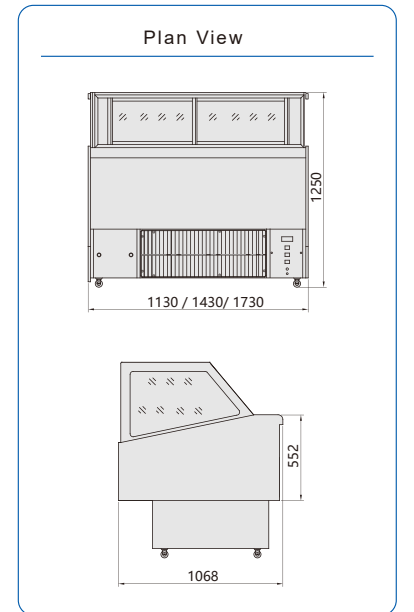
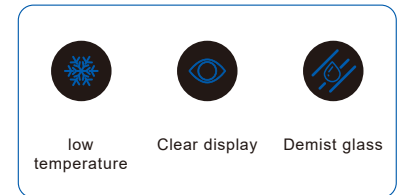

Product features

- Imported compressor
- All copper tube manufacturing
- Strong refrigeration, air cooling and frost free
- Digital temperature control, microcomputer intelligent and accurate temperature control
- Heating wire, degree film, hot gas demisting
- Natural marble base
- Universal caster

Product parameters

Model	GTS-ISB-1200	GTS-ISB-1500	GTS-ISB-1800
Product Size (mm)	1130×1068×1250	1430×1068×1250	1730×1068×1250
Temperature (°C)	-16 ~ -20	-16 ~ -20	-16 ~ -20
Capacity (L)	280	380	480
Power (W)	1000	1137	1516
Electric Current(A)	4.9	5.1	7.9
Gastronorm Containers	1/3×12	1/3×16	1/3×20

Product certification



* We have the right to change the product design and configuration without informing customers in advance!

45° CORNER GLASS ICE CREAM SHOWCASE

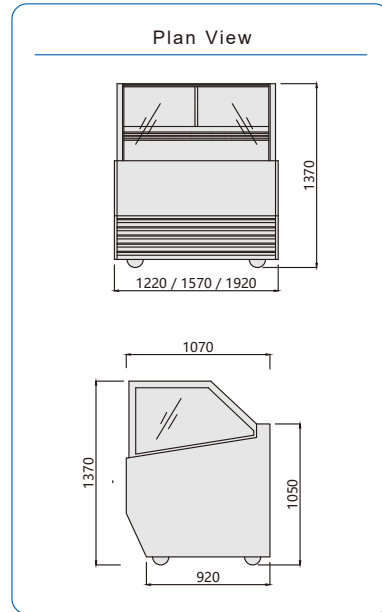
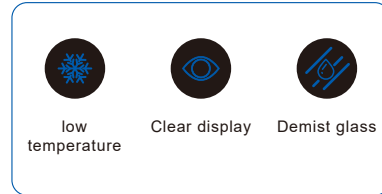

Product features

- Imported compressor
- All copper tube manufacturing
- Strong refrigeration, air cooling and frost free
- Digital temperature control, microcomputer intelligent and accurate temperature control
- Heating wire, degree film, hot gas demisting
- Natural marble base
- Universal caster

Product parameters

Model	GTS-IST-1200	GTS-IST-1500	GTS-IST-1800
Product Size (mm)	1220×1070×1370	1570×1070×1370	1920×1070×1370
Temperature (°C)	-16 ~ -20	-16 ~ -20	-16 ~ -20
Capacity (L)	380	480	580
Power (W)	1300	1450	1800
Electric Current(A)	4.9	5.1	7.9
Gastronorm Containers	1/3×12	1/3×16	1/3×20

Product certification



* We have the right to change the product design and configuration without informing customers in advance!

ARC ICE CREAM SHOWCASE

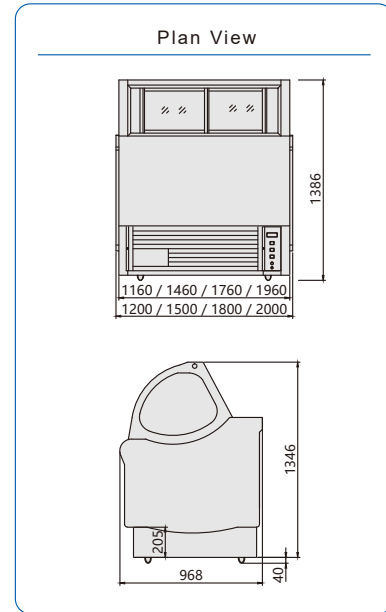
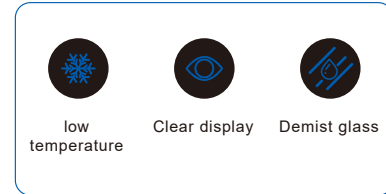

Product features

- Imported compressor
- All copper tube manufacturing
- Strong refrigeration, air cooling and frost free
- Digital temperature control, microcomputer intelligent and accurate temperature control
- Heating wire, degree film, hot gas demisting
- Natural marble base
- Universal caster

Product parameters

Model	GTS-ISW-1200	GTS-ISW-1500	GTS-ISW-1800	GTS-ISW-2000
Product Size (mm)	1200×968×1386	1500×968×1386	1800×968×1386	2000×968×1386
Temperature (°C)	-16 ~ -20	-16 ~ -20	-16 ~ -20	-16 ~ -20
Capacity (L)	380	480	580	680
Power (W)	900	1065	1450	1550
Electric Current(A)	4.9	5.0	7.4	7.9
Gastronorm Containers	1/3×12	1/3×16	1/×20	1/3×24

Product certification



* We have the right to change the product design and configuration without informing customers in advance!



MOUSSE SHOWCASE

Product features

- Europe brand controller
- European brand compressor
- All copper tube manufacturing
- Strong refrigeration, air cooling and frost free
- Stainless steel structure
- LED lighting
- Tempered thickened glass
- Double acting door
- The upper display freezer and the lower storage freezer

Product details



1. Europe brand controller
2. Random pattern stainless steel panel
3. Stainless steel edging design
4. Double layer hollow glass movable door
5. Laser dot luminescent board
6. Ultra white tempered glass

Product parameters

Model	GTS-HM1200
Product Size (mm)	1200×800×1400
Temperature (°C)	+2~+8
Capacity (L)	360
Power (W)	1090
Electric Current(A)	6.05
Net Weight (Kg)	150
Voltage (V)	220V/60HZ
Climate Class	4
Refrigerant (g)	R290/ 500

Product certification



* We have the right to change the product design and configuration without informing customers in advance!



International Standard Color Card
for Panel Paint and Coatings



Plan View

Front View

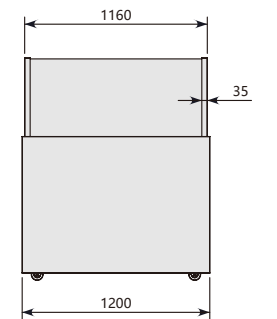

Back View

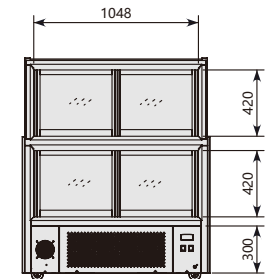

Side View

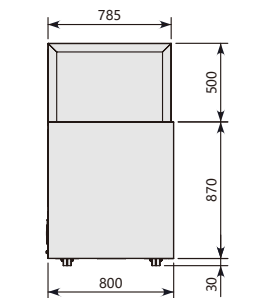

High quality stainless steel panel

- Random pattern stainless steel
- Silver stainless steel
- Black stainless steel
- White mirror stainless steel
- Black mirror stainless steel

AIR CURTAIN SHOWCASE

Product features

- Arc ultra white tempered glass
- High permeability PE material, telescopic microporous night curtain curtain
- LED lighting
- Reinforced universal casters for easier movement
- Stainless steel structure
- Ventilated cooling system
- High density insulation body
- Europe brand controller
- European brand compressor

Product details

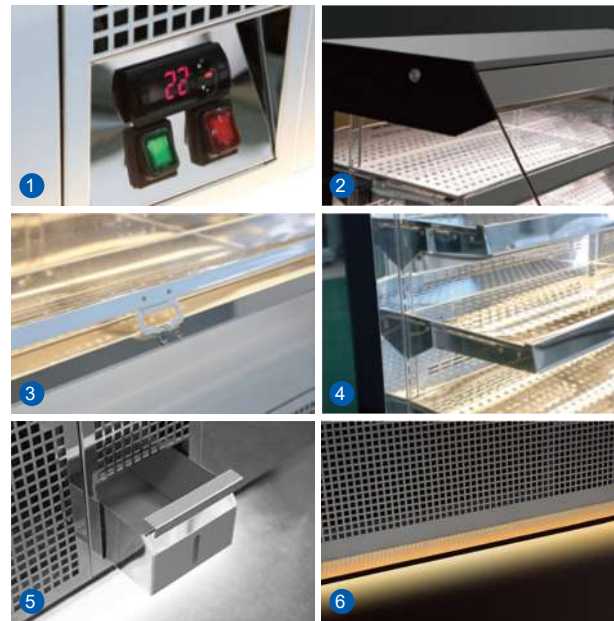

1. Europe brand controller
2. Front open inclined window
3. Telescopic microporous night curtain curtain
4. Stainless steel shelf and mesh stainless steel gasket
5. Drawer type water box with small window for visible water volume
6. Foot slot device lighting

Product parameters

Model	GTS-SLG-1875FD
Product Size (mm)	1500×800×1400
Temperature (°C)	+2~+8
Capacity (L)	464
Rated voltage (V)	220
Power (W)	1095
Electric Current(A)	5.74
Net Weight (Kg)	273
Climate type	N
Refrigerant (g)	R290/ 1000

Product certification



* We have the right to change the product design and configuration without informing customers in advance!



International Standard Color Card for Panel Paint and Coatings



Plan View

Front View

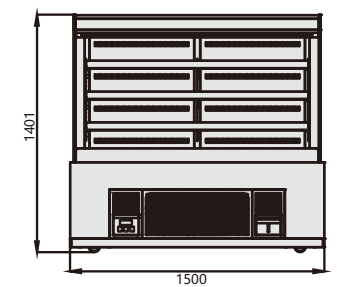

Side View

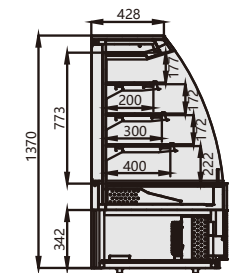

Vertical View

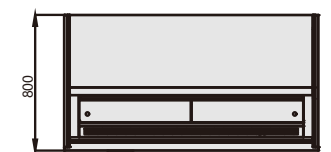

High quality stainless steel panel

- Random pattern stainless steel
- Silver stainless steel
- Black stainless steel
- White mirror stainless steel
- Black mirror stainless steel

DOUBLE ARC SUSHI SHOWCASE

Product features

- Stainless steel structure
- All copper tube refrigeration
- Tempered glass
- High sealing door seam
- Constant temperature control
- Europe brand digital controller
- Europe brand compressor
- LED lighting
- The chassis has drainage holes
- Split unit can be customized

Product details



1. Europe brand controller
2. Internal temperature display
3. Silver plated U-shaped copper tube refrigeration
4. Tempered glass sliding door
5. Double arc white tempered glass
6. Stable copper tube without deformation

Product parameters

Model	GTS-SS900	GTS-SS1200	GTS-SS1500	GTS-SS1800	GTS-SS2000
Product Size (mm)	900×400×380	1200×400×380	1500×400×380	1800×400×380	2000×400×380
Door height (mm)	275	275	275	275	275
Temperature (°C)	+4~+12	+4~+12	+4~+12	+4~+12	+4~+12
Rated voltage (V)	AC 220~230	AC 220~230	AC 220~230	AC 220~230	AC 220~230
Power (W)	-	-	-	215	224
Electric Current(A)	-	-	-	1.19	1.24
Refrigerant (g)	R290/-	R290/-	R290/-	R290/85	R290/93

Product certification



* We have the right to change the product design and configuration without informing customers in advance!

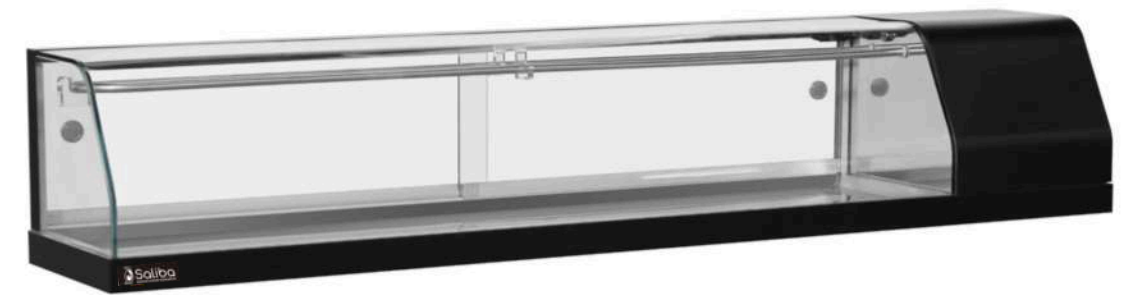
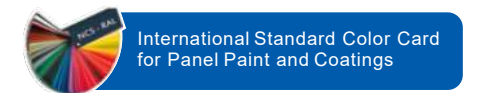

Black



Mirror steel

High quality stainless steel panel



The L-type cooler is on the left
The R-type cooler is on the right

Split unit can be customized

Plan View

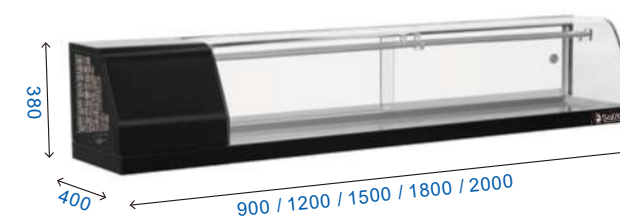

LED lighting

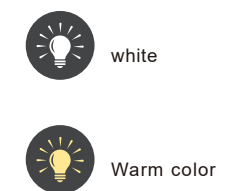

RIGHT ANGLE SUSHI SHOWCASE

Product features

- Stainless steel structure
- All copper tube refrigeration
- Tempered glass
- High sealing door seam
- Constant temperature control
- Europe brand digital controller
- Europe brand compressor
- LED lighting
- The chassis has drainage holes
- Split unit can be customized

Product details



1. Europe brand controller
2. Internal temperature display
3. Silver plated U-shaped copper tube refrigeration
4. Tempered glass sliding door
5. Water outlet
6. Cooling hole

Product parameters

Model	GTS-SS900	GTS-SS1200	GTS-SS1500	GTS-SS1800	GTS-SS2000
Product Size (mm)	900×400×380	1200×400×380	1500×400×380	1800×400×380	2000×400×380
Door height (mm)	275	275	275	275	275
Temperature (°C)	+4~+12	+4~+12	+4~+12	+4~+12	+4~+12
Rated voltage (V)	AC 220~230	AC 220~230	AC 220~230	AC 220~230	AC 220~230
Power (W)	-	-	-	215	224
Electric Current(A)	-	-	-	1.19	1.24
Refrigerant (g)	R290/-	R290/-	R290/-	R290/85	R290/93

Product certification



* We have the right to change the product design and configuration without informing customers in advance!

BAKERY'S HOWCASE



International Standard Color Card for Panel Paint and Coatings



Mirror steel



Luxury gold



Rose gold

High quality stainless steel panel



The L-type cooler is on the left
The R-type cooler is on the right

Split unit can be customized

Plan View

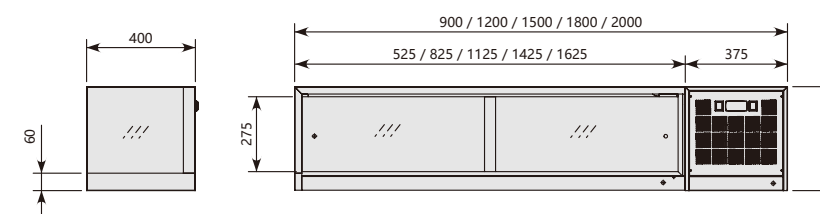

LED lighting



SERVING PLATE SUSHI CABINET



Arc



Rightangle

While the bottom of the cabinet is cooled, the top is also equipped with Φ 219mm cooling pipes to achieve uniform cooling effect. At the same time, because there is no vertical refrigeration pipe in the cabinet, the volume in the cabinet has been fully utilized.



The L-type cooler is on the left
The R-type cooler is on the right

Product features

- The constant temperature in the cabinet is 5 °C, which is the ideal food preservation temperature
- Inclined glass design enhances the effect of food display
- The top and bottom of the cabinet are cooled at the same time, with uniform cooling effect and stable cooling capacity
- The bottom is inclined, which makes cleaning more convenient

Product parameters

Model	GTS-SS4	GTS-SS5	GTS-SS6	GTS-SS7
Capacity (L)	42	57	72	87
Sliding door(PCS)	4	4	4	4
Product Size (mm)	1154×420×295	1330×420×295	1506×420×295	1680×420×295
Power (W)	150	150	150	150
Opening height(mm)	160	160	160	160
Temperature (°C)	5	5	5	5
Voltage (V)	220V 50Hz	220V 50Hz	220V 50Hz	220V 50Hz

Product certification



* We have the right to change the product design and configuration without informing customers in advance!

TRADITIONAL JAPANESE SUSHI CABINET

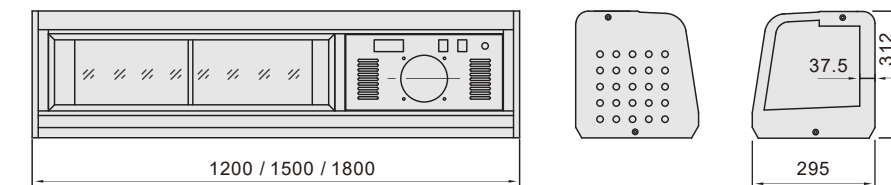

Product features

- All copper tube refrigeration
- Tempered glass
- High sealing door seam
- Constant temperature control

Product parameters

Model	GTS-SG-1200	GTS-SG-1500	GTS-SG-1800
Product Size (mm)	1200×295×312	1500×295×312	1800×295×312
Temperature (°C)	+4~+8	+4~+8	+4~+8
Capacity (L)	20	40	60
Power (W)	221	270	283
Electric Current(A)	1.4	1.6	2.3
Net Weight (Kg)	-	-	-
Voltage (V)	-	-	-

Product certification



* We have the right to change the product design and configuration without informing customers in advance!



BEVERAGE SHOWCASE SERIES



BLACK BEER CABINET (Vertical hinged door)

Product features

- Stainless steel structure
- Ventilated cooling system
- High density insulation body
- Europe brand controller
- European brand compressor
- Inner box mirror or aluminum stainless steel
- Automatic return double-layer insulating glass door
- Removable magnetic door seal
- Double layer upper and lower adjustable shelf
- Switchable LED light

Product details



1. Europe brand controller
2. Double layer upper and lower adjustable shelf
3. Exquisite door lock
4. Easy hinged door handle
5. Built in circulating fan cooling
6. Multiple door seals

Product parameters

Model	GTGS-LG138H	GTGS-LG208S	GTGS-LG330SEB
Product size (mm)	600×520×(800/850/900)	900×520×(800/850/900)	1350×520×(800/850/900)
Package size (mm)	650×570×(880/930/980)	950×570×(880/930/980)	1400×570×(880/930/980)
Temperature (°C)	0~+10	0~+10	0~+10
Net weight (Kg)	44/48/52	57/62/68	73/80/88
Net capacity (L)	110/120/130	170/185/205	265/290/320
Rated power (W)	180	230	265
Refrigeration type	Ventilated	Ventilated	Ventilated

Product certification



* We have the right to change the product design and configuration without informing customers in advance!



GTGS-LG208S



GTGS-LG138H



GTGS-LG330SEB

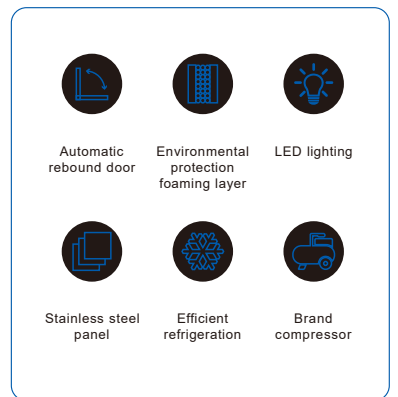

Plan View

Front View

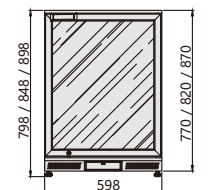

GTGS-LG138H



GTGS-LG208S

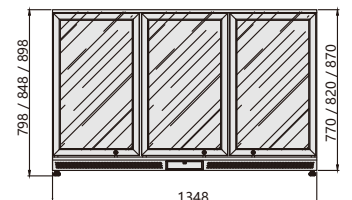

GTGS-LG330SEB

Side View

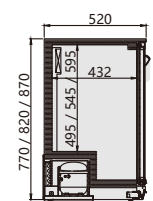

STAINLESS STEEL BEER CABINET (Primary color)

Product features

- Stainless steel structure
- Ventilated cooling system
- High density insulation body
- Europe brand controller
- European brand compressor
- Inner box mirror stainless steel
- Automatic return double-layer insulating glass door
- Removable magnetic door seal
- Double layer upper and lower adjustable shelf
- Switchable LED light

Product details



1. Europe brand controller
2. Double layer upper and lower adjustable shelf
3. Exquisite door lock
4. Vertical hinged door handle
5. Built in circulating fan cooling
6. Multiple door seals

Product parameters

Model	GTGS-LG138H-W	GTGS-LG208S-W	GTGS-LG330SEB-W
Product size (mm)	600×520×(800/850/900)	900×520×(800/850/900)	1350×520×(800/850/900)
Package size (mm)	650×570×(880/930/980)	950×570×(880/930/980)	1400×570×(880/930/980)
Temperature (°C)	0 ~ +10	0 ~ +10	0 ~ +10
Net weight (Kg)	44/48/52	57/62/68	73/80/88
Net capacity (L)	110/120/130	170/185/205	265/290/320
Rated power (W)	180	230	265
Refrigeration type	Ventilated	Ventilated	Ventilated

Product certification



*We have the right to change the product design and configuration without informing customers in advance!



GTGS-LG138H-W



GTGS-LG208S-W



GTGS-LG330SEB-W

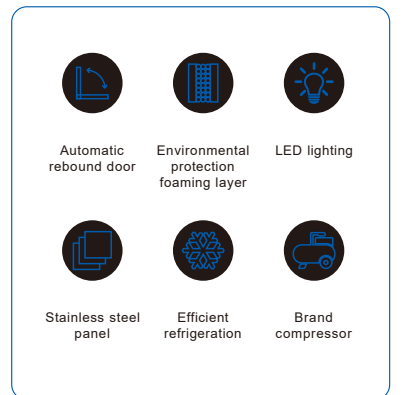

Plan View

Front View

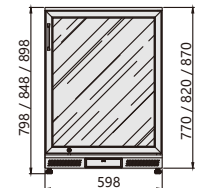

GTGS-LG138H-W

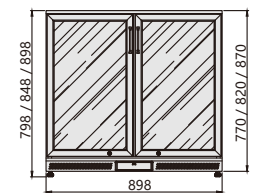

GTGS-LG208S-W

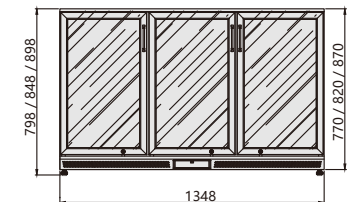

GTGS-LG330SEB-W

Side View

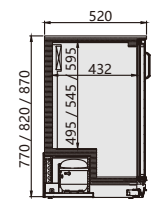



USER-FRIENDLY DESIGN



Adjustable Shelf Racks



Secure Fridge Lock



Convenient LED Display



Preinstalled Caster Wheels



UPRIGHT BEVERAGE COOLER

Product features

- Painted Stainless Steel Structure
- Static-Fan Assistant
- Self-Closing Door with Magnetic Gasket
- High Density Polyurethane Insulated Structure
- LED Light
- Easy to Clean Interior Structure
- Adjustable Shelves Desing
- EU Branded Compressor
- Digital Controller
- Automatic Defrozing System
- Adjustable Wheels are available
- R290 Gas

Product details



1. Europe brand controller
2. On-off switch
3. Exquisite door lock
4. Built in circulating fan cooling
5. Edged design four layer upper and lower adjustable shelves
6. Adjustable feet or castor is available
7. Internal led lighted
8. Black brushed stainless steel and gaskets

Product parameters

Model	GTGS-SSP380WA	GTGS-SSP1000WB-B	GTGS-SSP1500WAB
Product size (mm)	606×620×1940	1130×700×2030	1710×700×2063
Refrigerant	R290	R290	R290
Temperature (°C)	0~+10	0~+10	0~+10
Net weight (Kg)	85/90	179/195	255/270
Net capacity (L)	338	1000	1500
Rated power (W)	220-240 V 50 Hz	220-240 V 50 Hz	220-240 V 50 Hz
Refrigeration type	Static-Fan Assistant	Static-Fan Assistant	Static-Fan Assistant

Product certification



We have the right to change the product design and configuration without informing customers in advance!

BEVERAGE SHOWCASE SERIES



GTGS-SSP1500WAB

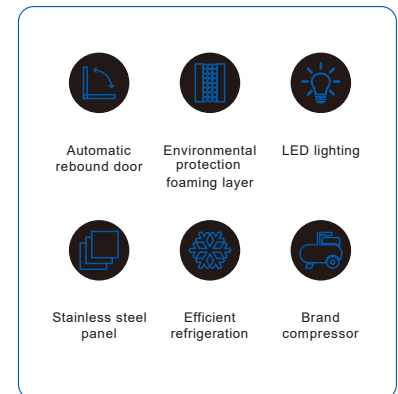

Plan View

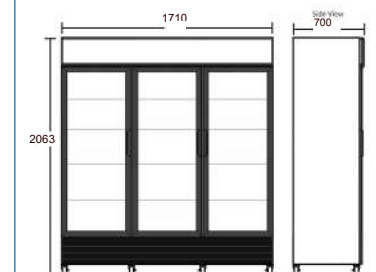
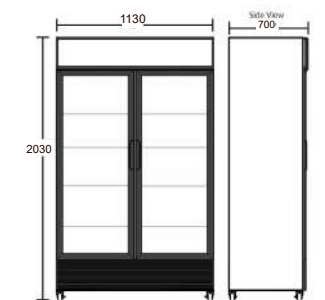
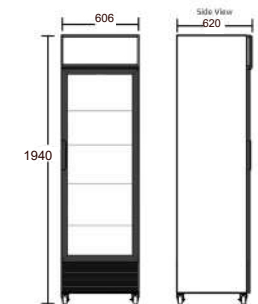

GTGS-SSP380WA



GTGS-SSP1000WB-B

UNDER COUNTER

Product features

- Europe standard GN 1/1 pan designed
- Stainless steel structure
- Ventilated cooling system
- High density insulation body
- Europe brand controller
- European brand compressor
- Smart automatic defrosting
- Interior body with round corner, easy to clean
- Self-closing door with magnetic gaskets
- Adjustable shelving design

Product details



1. Europe brand compressor
2. Adjustable shelving design
3. Fan cycle refrigeration
4. Embedded handle, simple and elegant



Product certification



*We have the right to change the product design and configuration without informing customers in advance!

Product parameters

Model	GTS-HBC0160	GTS-HBC0162	GTS-HBC0163	GTS-LBC0160	GTS-HBC0160G
Product Size (mm)	600×600×850	600×600×850	600×600×850	600×600×850	600×600×850
Temperature (°C)	+1 ~ +4	+1 ~ +4	+1 ~ +4	-10 ~ -18	+1 ~ +4
Shelf	2	x	x	2	2
Door	Solid Door	x	x	Solid Door	Glass Door
Refrigerant	R290	R290	R290	R290	R134A/R290
Capacity	40 Bottles For Bar	40 Bottles For Bar	40 Bottles For Bar	40 Bottles For Bar	40 Bottles For Bar

Model	GTS-HBC1160	GTS-HBC1162	GTS-HBC1163	GTS-LBC1160	GTS-HBC160G
Product Size (mm)	600×640×850	600×640×850	600×640×850	600×640×85	600×640×850
Temperature (°C)	+1 ~ +4	+1 ~ +4	+1 ~ +4	-10 ~ -18	+1 ~ +4
Shelf	2	x	x	2	2
Door	Solid Door	x	x	Solid Door	Glass Door
Refrigerant	R290	R290	R290	R290	R134a/R290
Capacity	40 Bottles For Bar	40 Bottles For Bar	40 Bottles For Bar	40 Bottles For Bar	40 Bottles For Bar

Model	GTS-HKC0150	GTS-HKC0152	GTS-HKC0153	GTS-LKC0150	GTS-HKC0150G
Product Size (mm)	600×600×820	600×600×820	600×600×820	600×600×820	600×600×820
Temperature (°C)	+1 ~ +4	+1 ~ +4	+1 ~ +4	-10 ~ -18	+1 ~ +4
Shelf	2	x	x	2	2
Door	Solid Door	x	x	Solid Door	Glass Door
Refrigerant	R290	R290	R290	R290	R134a/R290
Capacity	For Kitchen	For Kitchen	For Kitchen	For Kitchen	For Kitchen

Model	GTS-HKC1150	GTS-HKC1152	GTS-HKC1153	GTS-LKC1150	GTS-HKC150G
Product Size (mm)	600X640X820	600X640X820	600X640X820	600X640X820	600X640X820
Temperature (°C)	+1 ~ +4	+1 ~ +4	+1 ~ +4	-10 ~ -18	+1 ~ +4
Shelf	2	x	x	2	2
Door	Solid Door	x	x	Solid Door	Glass Door
Refrigerant	R290	R290	R290	R290	R290
Capacity	For Kitchen	For Kitchen	For Kitchen	For Kitchen	For Kitchen



Solid Door



Two Drawers

H	High Temperature	15	150 Litres
B	Bottle	16	160 Litres
C	Counter	0	Solid Door
L	Low Temperature	2	Two Drawers
G	Glass Door	3	Three Drawers



AIR DRIED HANGING MEAT SHOWCASE



MEAT DISPLAY REFRIGERATOR

Product features

- Stainless steel structure
- Ventilated system
- High density insulation body
- Europe brand digital controller
- Europe brand compressor
- Automatic defrosting
- Self-closing door with magnetic gaskets
- Adjustable shelving
- Glass door is available
- Adjustable feet or castor is available
- Led light is available
- Freezer mode are added heating element in doorframe, keep no fog around doorframe

Product details



1. Europe brand controller
2. Lighting
3. Increase the load-bearing rod, ultra-high load-bearing, not easy to deform

Product parameters

Model	GTS-GN1410-MDG
Product size (mm)	1480×830×2040
Refrigerant	R290
Temperature (°C)	-5~+5
Net weight (Kg)	197
Net capacity (L)	1285
Rated power (W)	412
Refrigeration type	Ventilated

Product certification



* We have the right to change the product design and configuration without informing customers in advance!

AIRDRIED, HANGING MEAT SHOWCASE



R290 TN: -5~+5°C

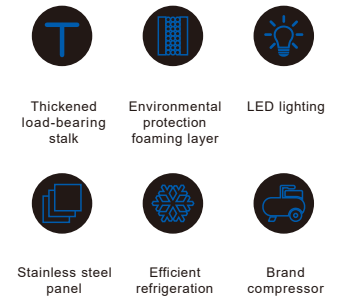

Plan View

Front View

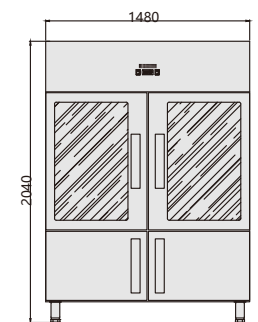

Vertical View

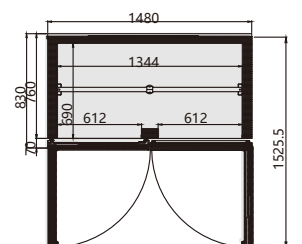

Side View

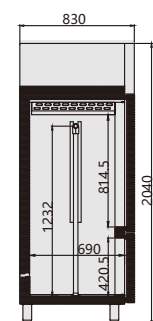

LOWER HANGING MEAT CABINET

Product features

- Stainless steel structure
- Ventilated system (no wind)
- High density insulation body
- Europe brand digital controller
- Europe brand compressor
- Self-closing door with magnetic gaskets
- Adjustable feet or castor is available
- Refrigeration unit lower
- Including T-shaped hanging rod
- LED lighting
- Front and rear visual glass
- Optional double side evaporator and upper evaporator

Product details



1. Europe brand controller
2. LED lighting
3. Increase the load-bearing rod, ultra-high load-bearing, not easy to deform

Product parameters

Model	GTS-GN1410-MDG
Product size (mm)	1480×830×2040
Refrigerant	R290
Temperature (°C)	-5 ~ +5
Net weight (Kg)	212
Net capacity (L)	1225
Rated power (W)	412
Refrigeration type	Ventilated

Product certification



* We have the right to change the product design and configuration without informing customers in advance!

AIRDRIED, HANGING MEAT SHOWCASE



R290 TN: -5~+5°C



- Thickened load-bearing stalk
- Front and rear visual glass
- LED lighting
- Stainless steel panel
- Efficient refrigeration
- Brand compressor

Plan View

Front View

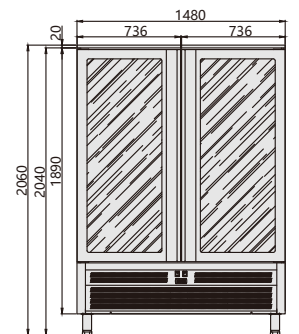

Back View

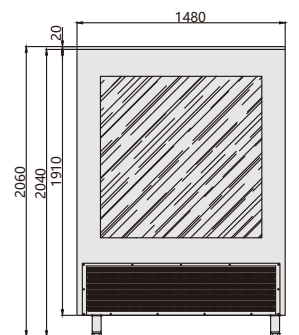

Side View

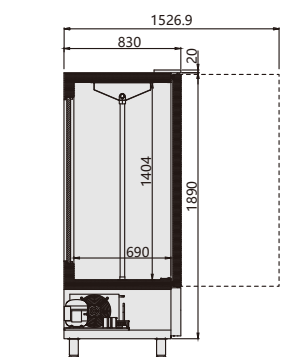

LUXURY AIR-DRYING CABINET

Product features

- High efficiency unit, all copper two.
- Intelligent refrigeration dehumidification integrated temperature controller.
- Plate: 0.5mm thick 201 stainless steel for inner and outer boxes.
- Control panel: 0.8mm thick.
- The overall high-density foaming layer of environmental protection foaming material is 60mm, with excellent thermal insulation effect.
- Double layer hollow antifogging glass door,
- Bright LED light.
- Equipped with 4 duck drying poles, high-speed strong air drying fan and oil pan.

Product details



1. High speed strong air drying fan, circulating cold and hot air drying
2. Push button digital control panel
3. Bright LED light

Product parameters

Model	GTS-JF600C	GTS-JF1200C	GTS-JF1800C
Product size (mm)	660×800×2040	1340×800×2040	2010×800×2040
Refrigerant	R290	R290	R290
Temperature (°C)	0~+25	0~+25	0~+25
Net weight (Kg)	105	201	-
Net capacity (L)	500	1000	1600
Rated power (W)	600	1000	1200
Refrigeration type	Cold hot air drying	Cold hot air drying	Cold hot air drying

Product certification



* We have the right to change the product design and configuration without informing customers in advance!

AIRDRIED, HANGING MEAT SHOWCASE



R290 TN: 0~+25°C



Thaw



Air-dry



Fresh

It is suitable for roast meats and other foods.

Plan View

Front View

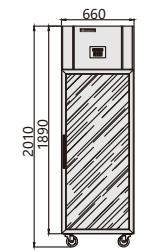

GTS-JF600C

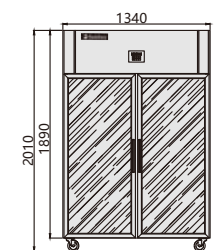

GTS-JF1200C

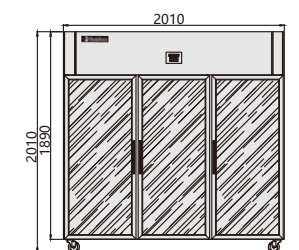

GTS-JF1800C

Side View

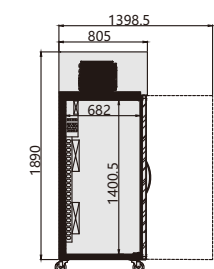

GTS-JF1200C



GTS-JF600C



GTS-JF1800C

SOLID WASTE REFRIGERATOR



OTHER SERIES



More products to meet your needs

www.salibaequipment.com

ICE STORAGE CABINET

Product features

- Stainless steel structure
- Ventilated cooling system
- High density insulation body
- Europe brand controller
- European brand compressor
- Smart automatic defrosting
- Interior body with round corner, easy to clean
- Large capacity ice storage
- Adjustable shelving design
- LED lighting.

Product details



1. Built in temperature sensor
2. LED lighting
3. Stainless steel door or glass door can be installed



Model	Product Size(mm)	Door Size(mm)
GTS-ICE380	1220×890×1900	690×690



Model	Product Size(mm)	Door Size(mm)
GTS-ICE600	1830×890×1900	690×690 (Door)

Product certification



* We have the right to change the product design and configuration without informing customers in advance!

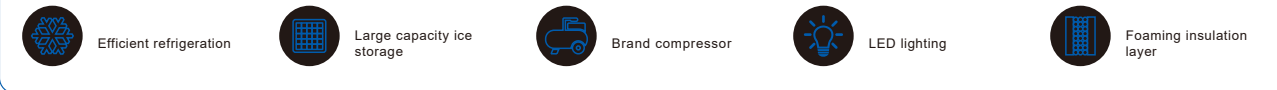

Model	Product Size(mm)	Door Size(mm)
GTS-ICE300	915×765×2065	640×1150
GTS-ICE420	1220×765×2065	710×1150
GTS-ICE630	1570×890×2065	710×1150



Model	Product Size(mm)	Door Size(mm)
GTS-ICE300G	915×765×2065	640×1150
GTS-ICE420G	1220×765×2065	710×1150
GTS-ICE630G	1570×890×2065	710×1150



Model	Product Size(mm)	Door Size(mm)
GTS-ICE650	1830×765×2065	640×1150 (2Door)
GTS-ICE670	1570×890×2065	640×1150 (2Door)
GTS-ICE750	1830×890×2065	640×1150 (2Door)
GTS-ICE850	2130×890×2065	710×1150 (2Door)
GTS-ICE1000	2250×890×2065	710×1150 (2Door)



Model	Product Size(mm)	Door Size(mm)
GTS-ICE650G	1830×765×2065	640×1150 (2Door)
GTS-ICE670G	1570×890×2065	640×1150 (2Door)
GTS-ICE750G	1830×890×2065	640×1150 (2Door)
GTS-ICE850G	2130×890×2065	710×1150 (2Door)
GTS-ICE1000G	2250×890×2065	710×1150 (2Door)

SOLID WASTE REFRIGERATOR

Product features

- Built in cooling: the automatic defroster and frost holding water are evaporated by hot gas. The refrigeration unit is suitable for plug-in operation at an ambient temperature of 43 °C

Product details



Europe brand compressor

Hydraulic flap

Equipped with door lock key

Seal the door seal

Product parameters

Model	GTS-SGC12001	GTS-SGC12002	GTS-SGC12003
Product size (mm)	1140×730×1125mm	1710×730×1125mm	2380×730×1125mm
Cover opening height(mm)	1450mm	1450mm	1450mm
Door opening depth(mm)	1310mm	1310mm	1310mm
Temperature (°C)	+2°C/+15°C	+2°C/+15°C	+2°C/+15°C
Total capacity(L)	340L	750L	1150L
Capacity(L)	1×120L	2×120L	3×120L
Negative cut(W/V)	440W/230V	440W/230V	580W/230V
Power consumption(KW/H)	1.9KW/24H	1.9KW/24H	1.9KW/24H

Model	GTS-SGC24001	GTS-SGC24002	GTS-SGC24003
Product size (mm)	1140×925×1250mm	1910×925×1250mm	2680×925×1250mm
Cover opening height(mm)	1590mm	1590mm	1590mm
Door opening depth(mm)	1460mm	1460mm	1460mm
Temperature (°C)	+2°C/+15°C	+2°C/+15°C	+2°C/+15°C
Total capacity(L)	520L	1120L	1710L
Capacity(L)	1×240L	2×240L	3×240L
Negative cut(W/V)	440W/230V	440W/230V	580W/230V
Power consumption(KW/H)	1.9KW/24H	1.9KW/24H	1.9KW/24H

Product certification



* We have the right to change the product design and configuration without informing customers in advance!



COOLING WELLS

Product features

- Embedded on the table for use
- Offset design of the unit to maximize the use of space under the platform
- Designed according to GN1/1 batch size
- Stainless steel structure
- Ventilated cooling system
- High density insulation body
- Europe brand controller
- European brand compressor

Product details



1. Europe brand controller
2. Designed according to GN1/1 batch size
3. Cooling wells are designed to be build into a counter

Product parameters

Model	GTS-TD-788EC	GTS-TD-1122EC	GTS-TD-1456EC	GTS-TD-1790EC
Product size (mm)	788×688×636	1122×688×636	1456×688×636	1790×688×636
Gastronorm Pans	2×GN1/1	3×GN1/1	4×GN1/1	5×GN1/1
Temperature (°C)	+2 ~ +8	+2 ~ +8	+2 ~ +8	+2 ~ +8
Gross / Net weight (kg)	46 / 38	52 / 42	58 / 46	64 / 50
Net capacity (L)	74	110	146	183
Rated power (W)	122	122	235	235
Refrigerant Type	R290	R290	R290	R290
Refrigeration type	Ventilated	Ventilated	Ventilated	Ventilated

Product certification



* We have the right to change the product design and configuration without informing customers in advance!



GN Pans Configurations

TD-788EC	1/1	1/1			
TD-1122EC	1/1	1/1	1/1		
TD-1456EC	1/1	1/1	1/1	1/1	
TD-1790EC	1/1	1/1	1/1	1/1	1/1

Plan View

Front View

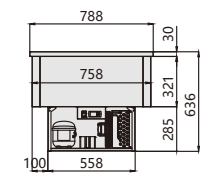

GTS-TD-788EC

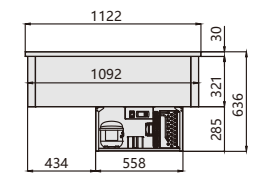

GTS-TD-1122EC

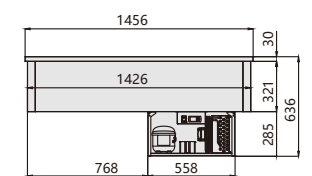

GTS-TD-1456EC

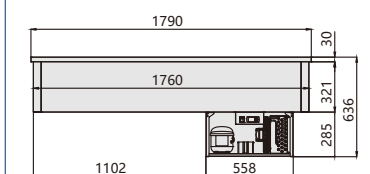

GTS-TD-1790EC

Side View

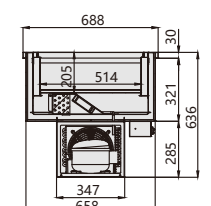



TABLE TOP SERIES



COOKERS AND FRYERS



Product parameters

Model	GTKARI-C4070E	GTKARI-C8070E	GTKARI-GF1270EC
Product size (mm)	400×700×290mm	800×700×290mm	600×600×290mm
Burner plates	2	4	Smooth
Product material	Stainless Steel	Stainless Steel	Stainless Steel
Temperature (°C)	90-450°C	90-450°C	90-450°C
Net Weight (Kg)	17Kg	35Kg	47Kg
Power consumption(KW/H)	5.2 KW/24H	10.4KW/24H	10.8KW/24H
Voltage (V/HZ)	400V~50HZ	400V~50HZ	400V~50HZ

Model	GTKARI-GF6060E GTKARI-GF4060EC	GTKARI-GF8070E GTKARI-GF8070EC	GTKARI-GF4060E
Product size (mm)	400×600×290mm 400×600×290mm	800×600×290mm	800×700×290mm
Burner plates	Smooth Krom	Smooth Krom	Grill Krom
Product material	Stainless Steel/ Krom	Stainless Steel/ Krom	Stainless Steel/ Krom
Temperature (°C)	300°C	300°C	2 Thermostat Control
Net Weight (Kg)	40 Kg 47 Kg	71 Kg 103 Kg	76 Kg
Power consumption(KW/H)	3KW/24H 6KW/24H	9.6KW/24H	Gas 13.8KW/24H
Voltage(V/HZ)	400W~50HZ	400V~50HZ	Natural Gas 1.452 m ³ /h Propan Gas 0.418 Kg/h

Product certification



* We have the right to change the product design and configuration without informing customers in advance!

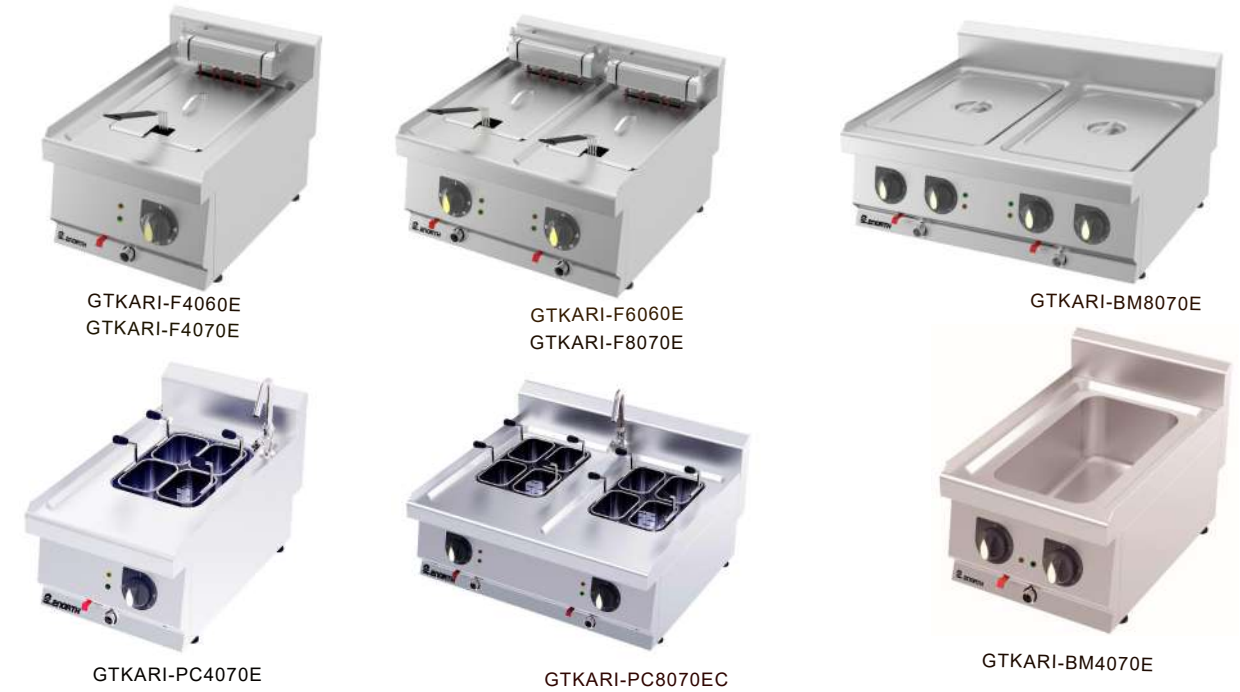

Product parameters

Model	GTKARI-F4060E	GTKARI-F6060E	GTKARI-F8070E	GTKARI-F4070E
Product size (mm)	400×600×290mm	600×600×290mm	800×700×290mm	600×700×290mm
Fryers (No/Lt)	1 (12Lt)	2 (12+12Lt)	2 (13+13Lt)	1 (12Lt)
Product material	Stainless Steel	Stainless Steel	Stainless Steel	Stainless Steel
Temperature (°C)	180°C	180°C	180°C	180°C
Net Weight (Kg)	37Kg	45Kg	49Kg	37Kg
Power consumption(KW/H)	9KW/24H	18 KW/24H	18KW/24H	9KW/24H
Voltage (V/HZ)	400V~50HZ	400V~50HZ	400V~50HZ	400V~50HZ

Model	GTKARI-PC4070E	GTKARI-PC8070EC	GTKARI-BM8070E	GTKARI-BM4070E
Product size (mm)	400×700×290mm	800×700×290mm	800×700×290mm	410×410×290mm
Fryers (No/Lt)	12Lt	2 (12+12Lt)	2 (12+12Lt)	230
Product material	Stainless Steel	Stainless Steel	Stainless Steel	Stainless Steel
Temperature (°C)	30-120°C	30-120°C	85-90°C	110°C
Net Weight (Kg)	47 Kg	35 Kg	28Kg	25 Kg
Power consumption(KW/H)	4.5KW/24H	9KW/24H	2KW/24H	1KW/24H
Voltage(V/HZ)	400V~50HZ	400V~50HZ	230 V~50HZ	230 ~50HZ

Product certification



ELECTRIC CLAMP GRILLS



GTKARI-RN101-A



GTKARI-RN103-A

Product parameters

Model	GTKARI-RN101-A	GTKARI-RN103-A
Product size (mm)	410×410×205mm	545×410×205mm
Burner plates	Grill	Grill
Product material	Stainless Steel	Stainless Steel
Temperature (°C)	300°C	300°C
Net Weight (Kg)	29Kg	37Kg
Power consumption(KW/H)	2.25 KW/24H	3.20KW/24H
Voltage (V/Hz)	230V~50HZ	230V~50HZ

Product certification



* We have the right to change the product design and configuration without informing customers in advance!

KEBAB GRILLS

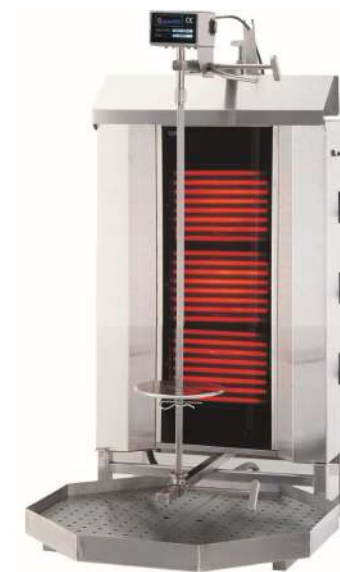

GTKARI-KLG230HG



GTKARI-KLG231HG



GTKARI-KLG232HG

Product parameters

Model	GTKARI-KLG230HG (30Kg)	GTKARI-KLG231HG (50Kg)	GTKARI-KLG232HG (70Kg)
Product size (mm)	550×700×960mm	550×700×1120mm	550×700×1285mm
Burner heating zones	3	4	5
Product material	Stainless Steel	Stainless Steel	Stainless Steel
Temperature (°C)	300°C	300°C	300°C
Net Weight (Kg)	25Kg	35Kg	45Kg
Power consumption(KW/H)	5.4KW/24H	7.6KW/24H	9KW/24H
Voltage (V/Hz)	400V~50HZ	400V~50HZ	400V~50HZ

Product certification



KEBAB GRILLS

Product features

- Automatic Electric Kebab Grill 50
- Remote Technical support can be provided via remote access.
- Several language options and a user-friendly control panel.
- Cylindrical, conical or reverse conical cutting function.
- Adjustable cutting thickness, standard cut and wide cutting options.
- Adjustable speed for cutting and rotation.
- Options for left and right arm.
- Several cooking options depending on the type of meat.
- Efficiency with minimal waste.
- The parts can be easily taken apart and cleaned.
- It has an ergonomic knife sharpening position.
- Water bath system to keep the meat warm and moist.



GTKARI-RODO4G



GTKARI-RODO5G

Product parameters

Model	GTKARI-RODO4G (50Kg)	GTKARI-RODO5G (70Kg)
Product size (mm)	750x800x1120mm	750x800x1290mm
Burner heating	4	5
Product material	Stainless Steel	Stainless Steel
Temperature (°C)	300°C	300°C
Net Weight (Kg)	115 Kg	125 Kg
Power consumption(KW/H)	10.2KW/24H	16.25KW/24H
Voltage(V/HZ)	230V~50HZ	230V~50HZ

Product certification



* We have the right to change the product design and configuration without informing customers in advance!



GTKARI-RODO4E



GTKARI-RODO5E

Product parameters

Model	GTKARI-RODO4E (50Kg)	GTKARI-RODO5E (70Kg)
Product size (mm)	825x800x1120mm	825x800x1275mm
Burner heating	4	5
Product material	Stainless Steel	Stainless Steel
Temperature (°C)	300°C	300°C
Net Weight (Kg)	115Kg	125 Kg
Power consumption(KW/H)	7.2KW/24H	9KW/24H
Voltage(V/HZ)	230V~50HZ	230V~50HZ

Product certification



QUALITY FIRST CUSTOMER PRIORITY

Thousands of well-known enterprises have reached long-term cooperation with us



Blank lined page for notes.

Blank lined page for notes.

A series of horizontal dotted lines for handwriting practice, spanning the width of the page.

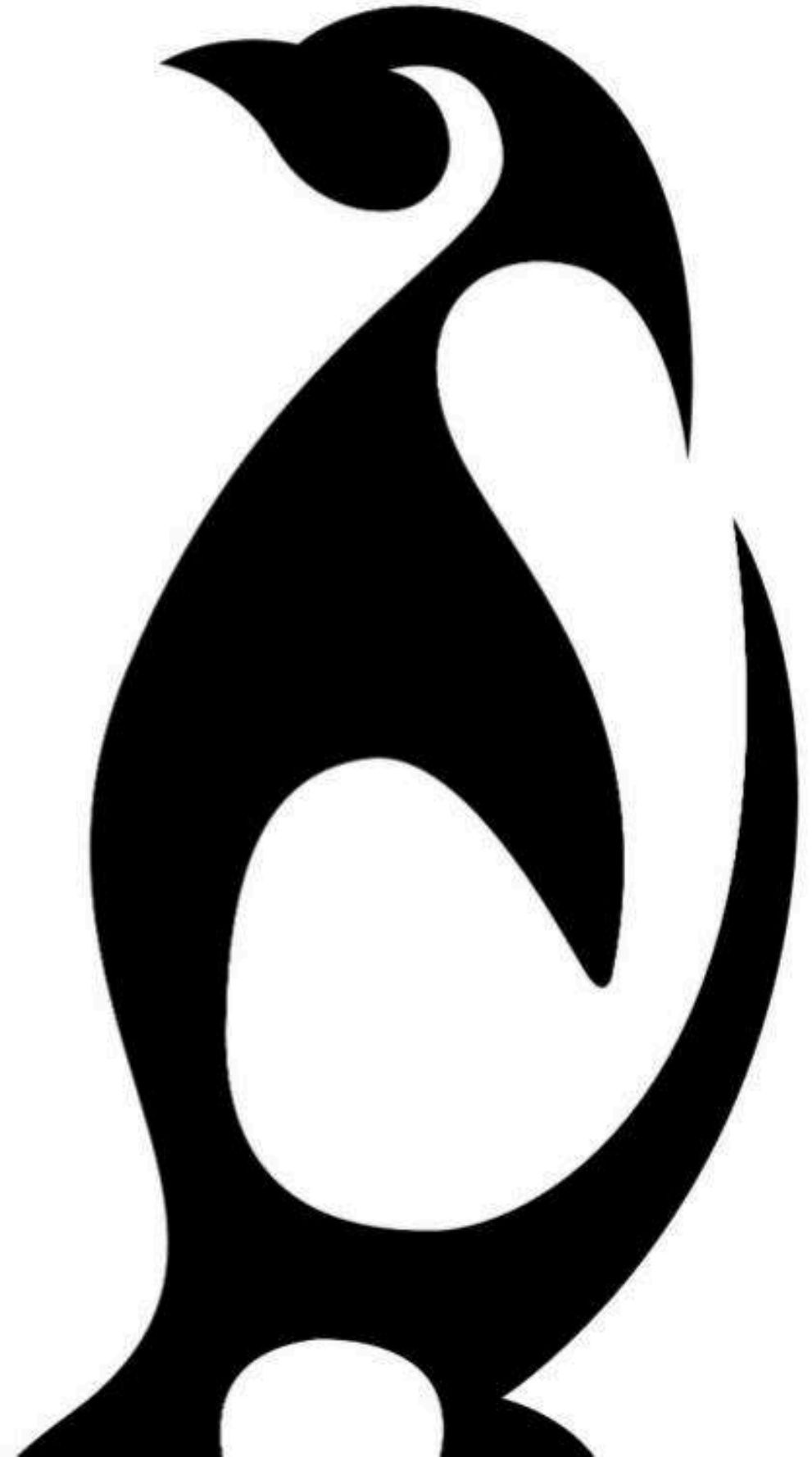



Saliba

SWEDISH KITCHEN EQUIPMENTS

GastroTeam Abbe AB

VAT-Nr: 559101-1100

Mekanikervägen 6

564 35 Bankeryd

Sweden

Tel: +46 (0) 36-777 90 90

E-mail: export@salibaequipment.com

Web: www.salibaequipment.com